

## CLINICAL REPORT

## Analysis of the CDKN2A and CDK4 Genes and HLA-DR and HLA-DQ Alleles in Two Spanish Familial Melanoma Kindreds

E. NAGORE<sup>1</sup>, J. CLIMENT<sup>2</sup>, M. D. PLANELLES<sup>3</sup>, E. LEDESMA<sup>1</sup>, F. RUBIO-MOSCARDÓ<sup>1</sup>, J. M. FORTEA<sup>1</sup> and V. OLIVER<sup>1</sup><sup>1</sup>Department of Dermatology, University General Hospital, <sup>2</sup>Laboratorio de Diagnóstico Molecular Sistemas Genómicos and <sup>3</sup>Unidad de Biología Molecular, Centro de Transfusión de la Comunidad Valenciana, Valencia, Spain

Some confusion exists in the literature about which criteria should be used to define familial melanoma. This could explain the different reported frequencies of mutations in predisposing genes, mostly CDKN2A, in these patients. This study evaluated the human leucocyte antigen (HLA) class II genotype and the presence of mutations in CDKN2A and CDK4 genes in 2 families with very different clinical features. The family with a germinal mutation in exon 2 of CDKN2A (Gly<sub>101</sub>Try) presented the following clinical features: 3 first-degree affected members, 1 of whom had 2 melanomas, and all the melanomas appearing before 35 years of age. In contrast, the second family did not present any mutation in the studied genes and included 2 first-degree affected members diagnosed at over 45 years of age. Neither family showed an association with HLA genotype. Other genes are also involved in familial melanoma but, when the CDKN2A gene is affected, some clinical features seem to be uniform. **Key words:** melanoma; predisposition; genetic.

(Accepted September 18, 2000.)

Acta Derm Venereol 2000; 80: 440–442.

Eduardo Nagore, C/ Denia, 20-6a, 46006 Valencia, Spain.

E-mail: eduyame@meditex.es

Familial cutaneous malignant melanoma (CMM) accounts for approximately 10% of all melanoma cases and is inherited as an autosomal dominant trait, albeit with incomplete penetrance and variable expressivity. Linkage between locus 9p21 and familial melanoma was found in large pedigrees (1). Germline mutations in the cyclin-dependent kinase inhibitor 2A (CDKN2A) gene, which maps to the 9p21 chromosomal region and encodes the cyclin-dependent kinase inhibitor p16<sup>INK4a</sup>, have been detected in a high proportion of familial melanoma kindreds, suggesting that it is probably the main 9p21-linked melanoma susceptibility gene (2–6). The p16<sup>INK4a</sup> protein inhibits phosphorylation of retinoblastoma protein by the G1 cyclin-dependent kinases CDK4 and CDK6, thereby negatively regulating progression through G1 into the S phase of the cell cycle (7). Mutant p16 fails to arrest normal diploid cells in the late G1 phase (8). The recent identification of germline mutations within the exon 2 of CDK4 gene on chromosome 12q15 in 2 families suggests that this may be another candidate gene for predisposing to a few familial malignant melanomas (6, 9).

In addition, another region linked to melanoma susceptibility has been identified within chromosome 6p (10). Previous studies of familial melanoma and chromosome 6p have reported contradictory results concerning linkage to the

human leucocyte antigen (HLA) complex on chromosome 6 (10, 11).

A total of 10 subjects belonging to 2 CMM families was studied for mutations in the CDKN2A and CDK4 genes, by sequence analysis, and for type II HLA genotyping.

## CASE REPORTS

Two families (Fig. 1) were recruited for the study according to the following criteria: (i) families with 2 affected members, 1 of them being affected before the age of 50 years; or (ii) families with at least 3 affected members. All the patients were Caucasians and there was no history of consanguinity in any of the families. All the patients were examined at the Department of Dermatology in the University General Hospital, Valencia, Spain.

Family 1 presented 3 affected members: 2 of 4 siblings and their mother (who died from a melanoma). Both affected siblings also had 2 histologically confirmed dysplastic naevi, and 1 of them had 2 primary melanomas. The age at the melanoma diagnosis in affected members was 34, 19 and 24 years. Family 2 presented 2 affected members with melanomas diagnosed at 42 and 46 years of age.

After informed consent had been given, peripheral blood was

Family 1

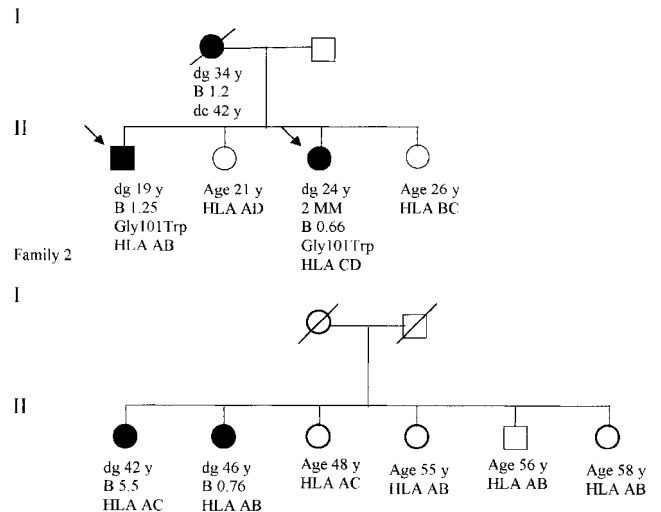

Fig. 1. Melanoma kindreds 1 and 2. Individuals with melanoma are represented by filled symbols and unaffected members by open symbols. Gly<sub>101</sub>Try, glycine to tryptophan substitution at nucleotide 301 (codon 101): patients with this mutation are indicated by an arrow. The age at diagnosis (dg) of affected individuals and current age (age) of unaffected individual are given. HLA alleles are also given (see also Table I). B: Breslow thickness (mm); 2MM: presence of 2 malignant melanomas.

Table I. Alleles for each family

| Allele          | Haplotype |           |                     |
|-----------------|-----------|-----------|---------------------|
|                 | DQA1*     | DQB1*     | DRB1*               |
| <i>Family 1</i> |           |           |                     |
| A               | 0101      | 0501–0504 | 0101/0102/0104–0106 |
| B               | 0102      | 0601–0616 | 1501–1508           |
| C               | 0501      | 0201–0202 | 0301/0304–0315      |
| D               | 0103      | 0601–0616 | 1301–1335           |
| <i>Family 2</i> |           |           |                     |
| A               | 0501      | 0201–0202 | 0301/0304–0315      |
| B               | 0201      | 0303/0306 | 0701–0704           |
| C               | 0101      | 0501–0504 | 0101/0102/0104–0106 |

obtained from each living member of the families. Genomic DNA was extracted from peripheral blood using standard procedures.

HLA-DQA, -DQB and -DRB genotyping was performed for all family members by polymerase chain reaction with sequence-specific primers (PCR-SSP) according to the method described previously (12, 13). HLA-DQA1\* was performed at a high resolution, but DRB1\* and DQB1\* were performed at a low resolution. A high resolution for DRB1\* and DQB1\* was not necessary because no association was found at a low resolution.

Sequencing was performed: (i) in every patient with a melanoma; and (ii) in the unaffected relatives of those patients with a melanoma who were carrying a mutation. DNA sequence analyses was performed on the 3 exons of the CDKN2A gene and exon 2 of the CDK4 gene as described previously (2, 3).

One heterozygous germline mutation in the CDKN2A gene was identified in family 1. The 2 remaining affected family members were found to carry the mutation (Fig. 1). It consisted of a G→T change at nucleotide 301 in exon 2, which alters a glycine to a tryptophan residue at position 101 (Gly<sub>101</sub>Trp) of the complete amino acid coding sequence (7) (Fig. 2). No sequence variations in exon 2 of the CDK4 gene were found in any melanoma patient examined. The HLA class II genotype did not correlate with the presence of melanoma. Moreover, in family 1, affected members presented completely different genotypes (Table I).

## DISCUSSION

A mutant germline CDKN2A allele was found in 1 of the 2 unrelated melanoma families. This mutation (Gly<sub>101</sub>Trp:

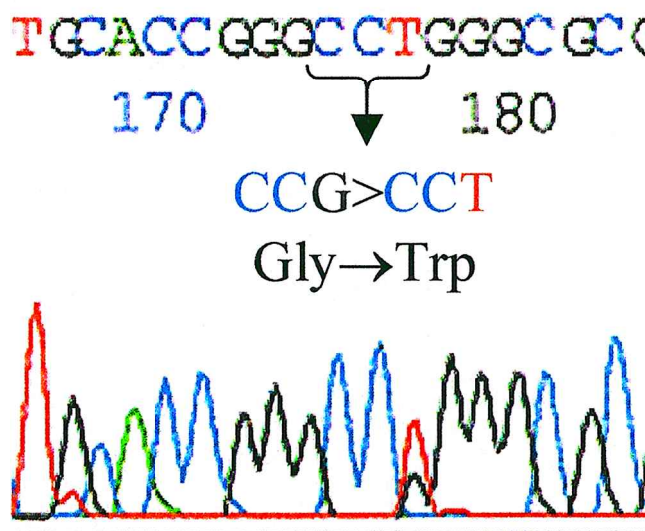

Fig. 2. G→T change at nucleotide 301 in exon 2, which alters a glycine to a tryptophan residue at position 101 (Gly<sub>101</sub>Trp) in the amino acid sequence.

301G→T) determines a mutant protein with no ability to inhibit the cyclin D1/CDK4 complex (14). It could represent a mutational hotspot because of the number of reported cases, especially in studies performed in Mediterranean countries (6, 15, 16). The second family had no mutations in CDKN2A or CDK4 genes expressing a random clustering of sporadic cases or an association with other alternative genes.

The results illustrate some confusion in the literature in defining familial melanoma, which could explain the different frequency of mutations in predisposing genes reported in familial melanoma pedigrees (1–6, 9, 15–17). Current data suggest that some features may be more relevant than others in determining who is at high risk of a melanoma because of genetic susceptibility (Table II).

Family 2, which had 2 melanoma-affected cases in first-degree relatives as the single characteristic, did not present mutations in CDKN2A or CDK4 genes. In contrast, family 1, with a mutation in the CDKN2A gene, presented 3 first-

Table II. Predictor clinical features of the likelihood of carrying a mutation in a melanoma susceptibility gene<sup>a</sup>

| Feature                                    | Comment   |
|--|---|
| Multiple relatives with cutaneous melanoma | Mutations have been found in:<br>20–40% of families with 3 or more affected members (2–4, 15, 17, 18)<br>5% of families with 2 members (18)   |
| Multiple primary cutaneous melanomas       | Mutations have been found in 0–15% of patients (15, 19). When family members of patients carrying a mutation were followed up, 1 study found that new melanoma arose in patients of 40% of the families (19)<br>When a family history of melanoma was also considered, mutations were found in 43% of the families (15) |
| Earlier age of onset of melanoma           | One study found the following median age at diagnosis (2):<br>53 years in the general population<br>39 years in patients with familial melanoma (33 years when carrying mutations; 41 years without mutations)  |
| Multiple naevi                             | In a study of melanoma kindreds, the total number of common naevi and of atypical naevi was higher among patients with mutations than without mutations (20)  |

<sup>a</sup>All data are related to CDKN2A, because it is at present the most important and best studied melanoma-predisposing gene.

degree affected members, 1 of whom had multiple melanomas, the presence of dysplastic naevi and age of diagnosis of 19, 24 and 34 years.

Families not presenting mutations in CDKN2A or CDK4 genes but complying with the characteristics of familial melanoma may have inherited other cancer-predisposition genes. Alternatively, other family-associated characteristics with lower penetrance, such as excessive sun exposure, or merely random clustering of sporadic cases, may be the cause.

No relation was found between any haplotype and melanoma in these families. Moreover, in family 1, the patients did not share any of the alleles. Previous reports studying the relation between HLA and melanoma have produced contradictory results. Whereas evidence suggesting linkage with a region included in the HLA complex in chromosome arm 6p has been described by some authors (10), others have found little or no role for a major chromosome 6 familial melanoma susceptibility locus (11).

In conclusion, genetic testing and counselling in melanoma patients who have a positive family history has raised expectations in health professionals and patients. However, given the current paucity of knowledge about melanoma susceptibility genes, it is considered premature by scientific authorities to offer DNA testing outside defined research protocols except in rare circumstances and only after careful genetic counselling (18). Further studies may help to improve our knowledge of genetic susceptibility in melanoma, and to define more accurately which cases should be considered as familial melanoma. In the future, such research could influence the medical management of the patient or family member.

## REFERENCES

- Nancarrow DJ, Mann GJ, Holland EA, Walker GJ, Beaton SC, Walters MK, et al. Confirmation of chromosome 9p linkage in familial melanoma. *Am J Hum Genet* 1993; 53: 936–942.
- Fitzgerald MG, Harkin DP, Silva-Arrieta S, MacDonald DJ, Lucchina LC, Unsal H, et al. Prevalence of germ-line mutations in p16, p19ARF, and CDK4 in familial melanoma: analysis of a clinic-based population. *Proc Natl Acad Sci USA* 1996; 93: 8541–8545.
- Flores JF, Pollock PM, Walker GJ, Glendening JM, Lin AH, Palmer JM, et al. Analysis of CDKN2A, CDKN2B, and CDK4 genes in 48 Australian melanoma kindreds. *Oncogene* 1997; 15: 2999–3005.
- Holland EA, Beaton SC, Becker TM, Grulet OM, Peters BA, Rizos H, et al. Analysis of p16 gene, CDKN2, in 17 Australian melanoma kindreds. *Oncogene* 1995; 11: 2289–2294.
- Yakobson EA, Zlotogorski A, Shafir R, Cohen M, Icekson M, Landau M, et al. Screening for tumor suppressor p16(CDKN2A) germline mutation in Israeli melanoma families. *Clin Chem Lab Med* 1998; 36: 645–648.
- Soufir N, Avril MF, Chompret A, Demenais F, Bombléd J, Spatz A, et al. Prevalence of p16 and CDK4 germline mutations in 48 melanoma-prone families in France. *Hum Mol Genet* 1998; 7: 209–216.
- Serrano M, Hannon GJ, Beach D. A new regulatory motif in cell-cycle control causing specific inhibition of cyclin D/CDK4. *Nature* 1993; 366: 704–707.
- Lukas J, Parry D, Aagaard L, Mann DJ, Bartkova J, Strauss M, et al. Retinoblastoma-protein-dependent cell-cycle inhibition by the tumor suppressor p16. *Nature* 1995; 375: 503–506.
- Zuo L, Weger J, Qingbei Y, Goldstein A, Tucker M, Walker G, Hayward N, Dracopoli N. Germline mutations in the p16INK4a binding domain of CDK4 in familial melanoma. *Nat Genet* 1996; 12: 97–99.
- Walker GJ, Nancarrow DJ, Walters MK, Palmer JM, Weber JL, Hayward NK. Linkage analysis in familial melanoma kindreds to markers on chromosome 6p. *Int J Cancer* 1994; 59: 771–775.
- Bale SJ, Greene MH, Murray C, Goldin LR, Johnson AH, Mann D. Hereditary malignant melanoma is not linked to the HLA complex on chromosome 6. *Int J Cancer* 1985; 36: 439–443.
- Olerup O, Zetterquist H. HLA DR typing by PCR amplification with sequence-specific primers (PCR-SSP) in 2 hours: an alternative to serological DR typing in clinical practice including donor–recipient matching in cadaveric transplantation. *Tissue Antigens* 1992; 39: 225–235.
- Olerup O, Aldener A, Fogdell A. HLA-DQB1 and -DQA1 typing by PCR amplification with sequence-specific primers (PCR-SSP) in 2 hours. *Tissue Antigens* 1993; 41: 119–134.
- Ranade K, Hussussian CJ, Sikorski RS, Varmus HE, Goldstein AM, Tucker MA, et al. Mutations associated with familial melanoma impair p16<sup>ink4</sup> function. *Nat Genet* 1995; 10: 114–116.
- Ruiz A, Puig S, Malvehy J, Lazaro C, Lynch M, Gimenez-Arnau AM, et al. CDKN2A mutations in Spanish cutaneous malignant melanoma families and patients with multiple melanomas and other neoplasia. *J Med Genet* 1999; 36: 490–493.
- Ghiorzo P, Mantelli M, Ciotti P, Ferrari C, Cafiero F, Grammatico P, et al. Italian melanoma prone families: analysis of CDKN2A/p16 mutations and linkage to 9p21. *Am J Hum Genet* 1996; 59 Suppl. A68.
- Fargnoli MC, Chimenti S, Keller G, Soyer HP, Dal Pozzo V, Hofler H, et al. CDKN2A/p16<sup>INK4a</sup> mutations and lack of p19<sup>ARF</sup> involvement in familial melanoma kindreds. *J Invest Dermatol* 1998; 111: 1202–1206.
- Kefford RF, Newton Bishop JA, Bergman W, Tucker MA. Counseling and DNA testing for individuals perceived to be genetically predisposed to melanoma: a consensus statement of the Melanoma Genetics Consortium. *J Clin Oncol* 1999; 17: 3245–3251.
- Monzon J, Ling L, Brill H, Goldstein AM, Tucker MA, From L, et al. CDKN2A mutations in multiple primary melanomas. *N Engl J Med* 1998; 338: 879–887.
- Wachsmuth RC, Harland M, Bishop JA. The atypical-mole syndrome and predisposition to melanoma. *N Engl J Med* 1998; 339: 348–349.