

From: The Isotope Laboratory of the Department of Obstetrics and Gynecology (Head: Prof. *A. Ingelman-Sundberg*) at Sabbatsbergs Hospital, Karolinska institutet, Stockholm, Sweden.

DISAPPEARANCE RATE OF SODIUM IONS FROM SUBMUCOUSLY INJECTED DEPOSITS IN THE ORAL VESTIBULE OF THE RABBIT

by

GÖSTA FORSSLUND

Sodium ions (Na^{22}), when injected locally, are rapidly transported away by the regional circulation flowing through the tissue containing the local deposit. In 1948 and 1949 *Kety* found that the so-called disappearance constant was closely related to the regional circulation.

A number of investigations have been made on the disappearance of radioactive sodium from different tissues. However, the submucous connective tissue of the oral cavity does not yet seem to have been investigated with this technique. In consideration of the generally accepted conception of the abundant circulation in the oral cavity, it would be of interest to measure this circulation and compare it with the circulation in other tissues. As the gingiva of the rabbit is not suitable for such investigations, and for periodontological and anatomical reasons, the author has chosen to investigate the oral vestibule. Information on disappearance measurements and on theoretical, technical, biological, and medical aspects can be obtained from the work of *Odeblad, Westin, & Englund* (1959).

EXPERIMENTAL TECHNIQUE

Ten adult rabbits weighing between 2 and 6 kg were used. Several of them were examined repeatedly. Thus, one rabbit was examined ten times. There were 36 examinations in all. The distribution is shown in Table 1. The rabbits were anesthetized

Table 1

Rabbit no.	Disappearance constants (k)									
1	0.35	0.36	0.25	0.25	0.50					
2	0.63	0.53	0.50	0.46	0.32	0.46	0.46	0.58		
3	0.43	0.36	0.24	0.46	0.36	0.32	0.25	0.32	0.50	0.35
4	0.36	0.23	0.32							
5	0.39	0.63	0.36							
6	0.30	0.39	0.28							
7	0.53									
8	0.43									
9	0.58									
10	0.46									

Grand mean 0.40 min.^{-1} Standard deviation ± 0.11 . (D.F. 35). Rabbit no 3; mean 0.36 min.^{-1} Standard deviation ± 0.08 (D.F. 9). The first values from 10 individual rabbits; mean 0.45 min.^{-1} Standard deviation ± 0.11 . (D.F. 9).

with 1.5—5.0 ml of *Nembutal* (Abbot) intravenously. The general circulation did not appear to be affected by the anesthetic. The animal was placed on its left side on a table. With a *Mantoux* syringe about 2 microcuries of Na^{22} in 0.02 ml of physiological saline solution were injected submucously into the oral vestibule, lateral to the right maxillary incisor and between the two frenums. The needles used had an outer diameter of 0.40 mm. The deposit was placed in front of the inlet of a directional scintillation counter. The cylindrical collimating channel in the 4 cm thick lead shield had an aperture of 1.7 cm and a length of 6.2 cm. The collimator (Fig. 1) was fixed to a stand arm and could

Fig. 1. The scintillation detector unit is shielded with lead, 4 cm thick and 10 cm high. Below the scintillation crystal there is a collimating channel in the lead shield with a diameter of 1.7 cm and a length of 6.2 cm. This equipment is mounted on a stand arm and can be elevated and lowered by means of a screw device.

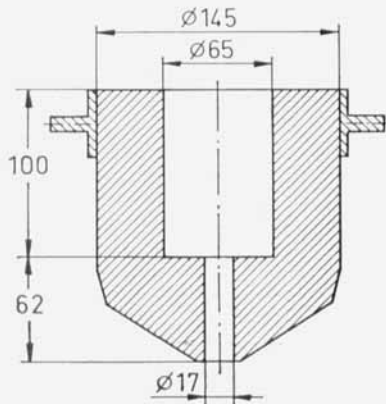
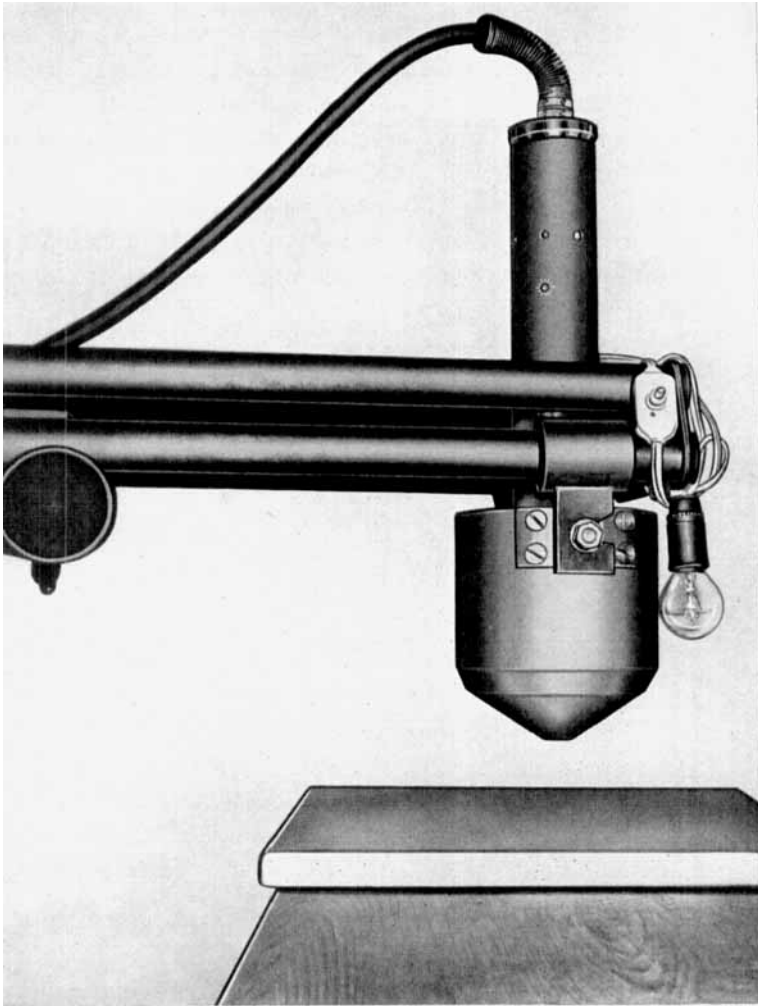

be elevated and lowered by means of a screw device. The distance from the deposit to the collimator was about 1.5 cm and to the crystal about 6.8 cm. The crystal was cylindrical, measuring 2.5 by 2.5 by 2.5 cm. Na²² gives off three penetrating gamma rays per disintegration with the energy of 0.51, 0.51, and 1.28 MeV, respectively. The counting rate was read every half minute on a ratemeter for at least 12 minutes, sometimes up to 20 minutes. In this work the time constant of the ratemeter was 10 seconds. The reading was started more than half a minute after the in-

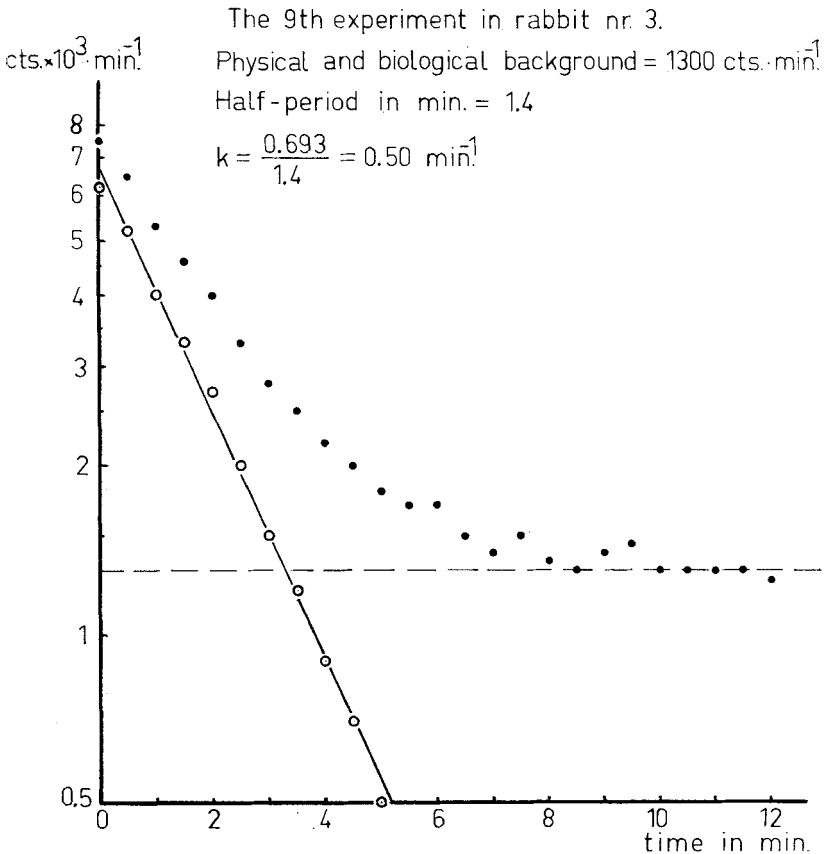

Fig. 2. An example of a disappearance measurement in a rabbit.
 ● = total counting rate per minute.
 -- = counting rate per minute of the total background.
 ○ = counting rate per minute after subtraction of the total background.
 The slope of this curve gives a disappearance constant of 0.50 min⁻¹.

jection of the deposit. The room temperature was between 19° C and 21° C. Correction for the exponentially rising animal background was performed as described in detail by *Odeblad, Westin, & Englund* (1959). The impulse rates, corrected for the biological and physical background, were plotted against time on a semi-logarithmic graph on which the exponential disappearance of the local activity was ascertained and the disappearance constant (k) evaluated (see Fig. 2).

RESULTS

The results are exemplified in Fig. 2, and the individual measurements are presented in Table 1.

The mean of the disappearance constants for all 36 experiments was 0.40 min.⁻¹ The standard deviation was ± 0.11 (25 %) and the error of the mean ± 0.019 .

The mean of the disappearance constants estimated from the first values obtained from 10 individual rabbits was 0.45 min.⁻¹ The standard deviation was ± 0.11 (24 %) and the error of the mean ± 0.033 .

The mean of the disappearance constants in one rabbit examined ten times was 0.36 min.⁻¹ The standard deviation was ± 0.08 (22 %) and the error of the mean ± 0.025 .

It can be seen from these figures and Table 1 that the variation between and within rabbits is approximately the same.

DISCUSSION

In the work of *Odeblad, Westin, & Englund* (1959, p. 56—57) a number of disappearance constants in different tissues are presented. The results of the present investigation indicate that the submucous regional circulation of the oral vestibule is higher than in most of the tissues investigated. Only two higher values have been observed. *Odeblad, Nati, Selin, & Westin* (1956) found a disappearance constant of 0.62 min.⁻¹ in the ovary of the rabbit which had been influenced by gonadotropic hormones. *Westin* (1957) reported a disappearance constant of 0.49 min.⁻¹ for the vaginal wall in castrated and hysterio-ovariectomized rats which were under influence of oestrogenic hormones. For comparison

it may be mentioned that the normal disappearance constant of striated muscle usually is about 0.050 min.^{-1} . In such intramuscular measurements the standard deviations usually amount to 15—20 per cent. These rather high values make the diagnostic use of an individual determination somewhat questionable (*Odeblad, Westin, & Englund, 1959*). This consideration also applies in the present investigation, the corresponding values being 22—25 per cent.

In discussing the present results and the standard deviations obtained, the depth of the anesthesia must be considered. *Westin & Odeblad (1955)* suggested that under Nembutal anesthesia in rats the disappearance rate of radiosodium may be lowered by a drop in the body temperature of the animals. Thus, if the depth of anesthesia is different in different experiments, the disappearance constant may vary accordingly. It is also known (*Johnson, 1951*) that in man there is a drop in the cardiac output and oxygen consumption of the body under intravenous barbiturate (*Narkotal, Astra*) anesthesia. A smaller standard deviation may therefore be obtained in non-anesthetized individuals. The average numerical value of the disappearance constant may also be higher without anesthesia.

Injection of a deposit into a tissue might result in a rise in the local hydrostatic pressure. This might give a retarded diffusion to the capillaries. *Westin (1957)* after injection of 0.01—0.02 ml of normal saline in the vaginal wall of the rat recorded an initial increase in local pressure of up to 10 mm mercury. This increase was rapidly reduced and was equalized in about 15 seconds. Thus, the small volume of 0.02 ml injected into the loose submucous connective tissue considered in this work probably did not interfere with the local circulation or cause tissue injury. The fact that the reading of the ratemeter was not started until half a minute after the injections should reduce such local pressure effects.

Acknowledgements

The author's thanks are due to Assistant Professor *Erik Odeblad* for valuable advice during the course of this work.

Financial assistance for this study was received from *the Swedish Dental Society*.

SUMMARY

Local disappearance of Na^{22}Cl was measured in the oral vestibule to obtain information on the regional circulation. The value of the disappearance constant was found to be 0.40 min.^{-1} which is among the highest of such values known in the organism. The standard deviation is large ($\pm 25 \%$). This large deviation also appeared when a single animal was examined repeatedly. The influence of anesthesia and local hydrostatic pressure on the results is discussed.

RÉSUMÉ

TAUX DE DISPARITION DES IONS SODIUM PROVENANT DE DÉPÔTS
APPORTÉS PAR INJECTION SOUS-MUQUEUSE DANS LE VESTIBULE DE
LA CAVITÉ BUCCALE DU LAPIN

La disparition locale du Na^{22}Cl a été mesurée dans le vestibule de la cavité buccale pour obtenir des renseignements sur la circulation régionale. La valeur de la constante de disparition trouvée était de $0,40 \text{ min.}^{-1}$. C'est une des plus hautes constantes de disparition parmi les valeurs connues dans l'organisme. L'erreur standard est grande ($\pm 25 \%$). Cette grande incertitude existe aussi lorsqu'on examine à plusieurs reprises un seul animal. L'influence de l'anesthésie et de la pression hydrostatique locale sur le résultat fait l'objet d'une discussion.

ZUSAMMENFASSUNG

DER ABTRANSPORT VON NATRIUMIONEN, INJIZIERT IN DIE
SUBMUCOSA DES VESTIBULUM ORIS BEIM KANINCHEN

Der lokale Abtransport von Na^{22}Cl wurde im Vestibulum oris gemessen, um Kenntnisse von der regionalen Zirkulation zu erhalten.

Die Grösse der Wegfall-Konstante betrug $0,40 \text{ Min.}^{-1}$, d. h. eine der schnellsten im Organismus. Die Abweichung beträgt etwa $\pm 25 \%$. Diese grosse Abweichung tritt auch auf, wenn dasselbe Tier wiederholt untersucht wurde.

Der Einfluss der Anaesthesie und des lokalen hydrostatischen Druckes auf diese Resultate wird diskutiert.

REFERENCES

- Johnson, S. R.*, 1951: The effect of some anaesthetic agents on the circulation in man with special reference to the significance of pulmonary blood volume for the circulatory regulation. Thesis. Stockholm. Acta chir. scand., Suppl. 158.
- Kety, S. S.*, 1948: Quantitative measurements of regional circulation by the clearance of radioactive sodium. Amer. J. med. Sci. 215, 352—353.
- 1949: Measurement of regional circulation by the local clearance of radioactive sodium. Amer. Heart J. 38, 321—328.
- Odeblad, E., G. Nati, B. Selin & B. Westin*, 1956: Some effects of gonadotropic hormones on the ovarian circulation in the rabbit. Acta endocr. Copenhagen, 22, 65—67.
- Odeblad, E., B. Westin & S. E. Englund*, 1959: Disappearance measurements. Theoretical, technical, biological, and medical aspects. Stockholm. Acta radiol. Stockh. Suppl. 173.
- Westin, B.*: Experimental studies on the disappearance of radiosodium ions from local deposits in the cavity and in the wall of the vagina of the rat. Thesis. Stockholm. Acta radiol. Stockh., Suppl. 144.
- Westin, B. & E. Odeblad*, 1955: Radiosodium (Na^{24}) clearance in hypo- and hyperthermic rats. Acta chir. scand., 109, 315—318.

Address: *Sabbatsbergs Sjukhus*
Stockholm Va
Sweden