

ARMAMENTARIUM FOR RADIUM TREATMENT OF CARCINOMA OF THE UTERINE CERVIX

by

O. KJELLGREN and I. RAGNHULT

Several different types of radium applicators have been developed since the radium treatment of carcinoma of the uterine cervix has become the method of choice. Radium therapy was previously extensively employed but since the introduction of the supervoltage therapy its use in primary treatment has become less general. It is however still considered the best primary method of dealing with most cases of cancer of the uterine cervix.

All means of applying radium in the treatment of carcinoma of the cervix of the uterus have derived from one of two fundamental methods, the Paris or the Stockholm method. Several of the current local radiation procedures in this condition are illustrated in Fig. 1.

The Paris method, a protracted low-intensity technique of radium treatment, was devised in the beginning of the nineteen twenties by REGAUD et coll. at the Radium Institute, Paris. It makes use of small quantities of radium applied for the fairly long time of about 5 days, the total dose amounting to about 8 000 mgh.

The Manchester method was developed from the Paris method; the main feature is the delivery of a predetermined dose to arbitrarily defined points in the pelvis, independently of the arrangement of the applicators; it entails

From the Gynecologic Section (Director: Herman Leissner) of the Department of Radiotherapy and from the Department of Radiophysics (Director: Sven Benner), University of Gothenburg, Sweden. Submitted for publication 14 May 1962.

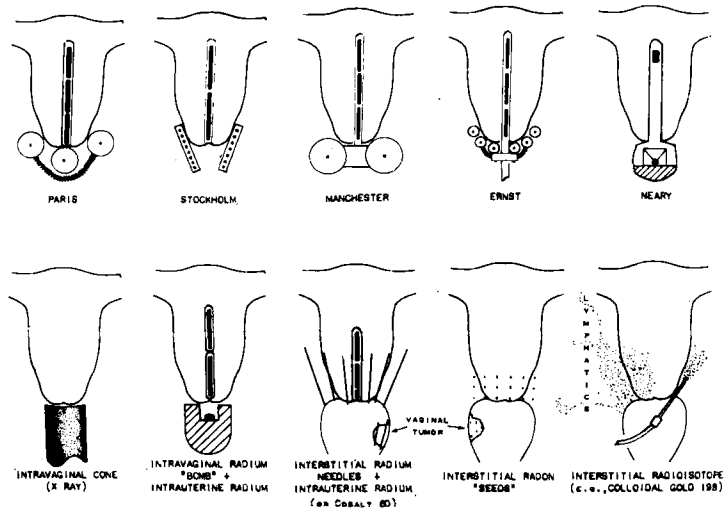

Fig. 1. After GRAHAM 1957.

differential loading of the applicators dependent upon their size and length. The optimal dose at point A, defined as 2 cm lateral to the uterine canal and 2 cm above the vaginal fornix, has been determined as 7 500 to 8 000 r in two treatments given with an interval of one week (TOD 1941, TOD & MEREDITH 1938).

The Stockholm method was originally devised by FORSELL & HEYMAN and has been further developed by KOTTMIEER at Radiumhemmet. The technique is based on repeated treatments with fairly large amounts of radium for a relatively short time, a number of different applicators being used. Advantage is taken of the possibilities of selecting the treatment with due regard to the type of the tumour and its spread, the patient's general condition, and so on. The length of the intrauterine applicators depends on the length of the uterus. The applicators as a rule are permanently loaded, contain from 53 to 88 mg radium, and are so designed that the dose rate 2 cm from the center of the applicator is about 75 r/h. The vaginal applicators, most of which are also permanently loaded, vary in shape and size and mostly contain 60 to 80 mg radium; the radium is usually spread towards the lateral parts of the boxes. The time of treatment generally amounts to about 27 hours at each of two sittings, 3 weeks apart. The total filtration is equivalent to 2 to 3 mm of lead. The dose at the bladder and the rectum is checked by dose measurements, making it possible to avoid overdosage in these organs by cutting down the treatment time when the dose rate is too high. The optimal total dose to the rectum from the radium is 4 000 r and to the bladder about 5 500 r. These doses are generally not exceeded in early stages of carcinoma of the cervix,

but up to 6 000 r may be given to the rectum in advanced stages (KOTTMEIER 1959).

The dose from the intrauterine applicator may be raised by increasing the time of treatment or the amount of radium. The diameter of the applicator is increased to 13 mm from the usual 7 mm in these cases, in order to avoid an excessive dose to the uterine wall. Experience has shown that dilatation of the cervical canal to Hegar 13 may generally be made without difficulty. A higher intrauterine dose is usually given in cases of endocervical carcinoma, paracervical growth, palpable metastases at the pelvic wall, or in cases with a narrow vagina. The vaginal dose must then be correspondingly decreased. Three weeks after the second application, roentgen or telecobalt treatment towards the parametria and pelvic walls is generally administered by the split field technique with two anterior and two posterior portals. Primary roentgen or telecobalt treatment through one large anterior portal, and one or two posterior portals, is given only in advanced cases or in cases with large cauliflower tumours. Perineal portals may also be used in the latter condition.

The dose administered to the cervix amounts to about 20 000 r but much less is received by the pelvic walls. Provided the intrauterine radium is not applied as far down as the external os, the dose at point A, with the current Stockholm method, amounts to about 6 000 r. With the radium at the external os, the dose to the cervix, at the rectum, and at point A increases, however. The dose on the pelvic walls from the intracavitary radium amounts to between 610 and 2 430 r, provided the uterus is situated in the center of the pelvis. The obturator nerve receives about 1 335 r, 60 to 70 % of which is from the intrauterine radium (KOTTMEIER 1953).

Detailed studies of the dose distribution in the pelvis with the Stockholm method have been made by KOTTMEIER (1951 and 1953) and WALSTAM (1954).

A number of special applicators for radium treatment of carcinoma of the cervix have been described and include Ernst's applicator, Neary's applicator, and the Buffalo applicator used at Roswell Park Memorial Institute. Interstitial radium needles in the tumour combined with intrauterine radium or Co^{60} , an 'intravaginal radium bomb' combined with intrauterine radium, or intravaginal roentgen irradiation through a vaginal cone, are other methods of local radiologic treatment. (For references see GRAHAM et coll. 1962.)

It is of great importance to be familiar with the method used and to be aware of the dose delivered to the different parts of the tumour and the pelvic organs regardless of which method is being used.

Armamentarium

A system of permanently loaded applicators for the radium treatment of carcinoma of the uterine cervix have been developed during recent years in our department, the applicators being similar to those used in the Stockholm

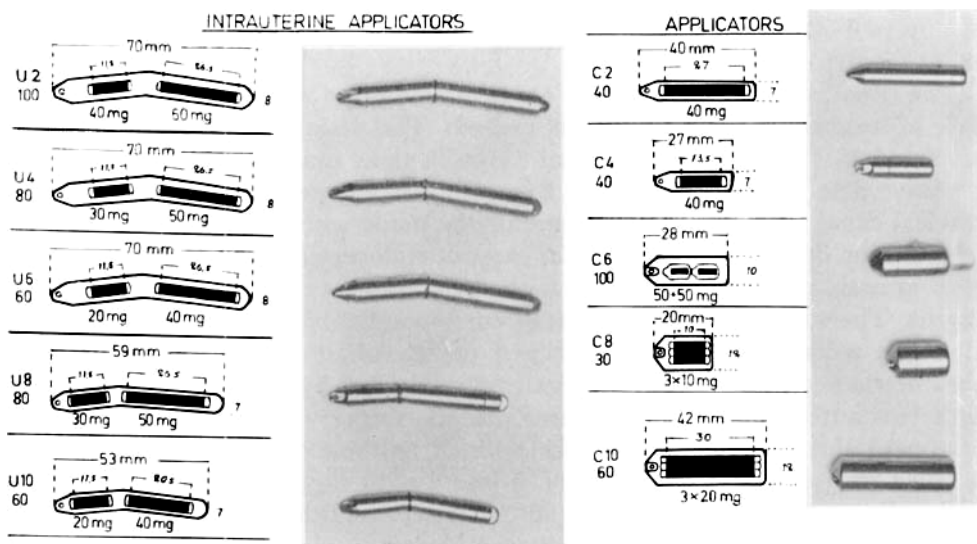

Fig. 2

method. The dose rate in r/h at a point 2 cm from the center of the intrauterine applicators is, however, not constant but numerically equal to the radium content in mg.

Primary radium treatment of carcinoma of the cervix with this armamentarium is generally given in three applications, 13 to 14 days apart. The interval is adjusted so that the second and third treatment will be administered at the time when the radiation reaction in the vaginal smear from the preceding treatment has reached its peak (KJELLGREN 1958). If the tumour is confined to the portio or the vagina the first two treatments usually consist of combined intrauterine and vaginal applications and the third only a vaginal application. An intrauterine application is given at the third treatment if the tumour is of endocervical origin or has a large paracervical spread.

Five different intrauterine applicators (U2, U4, U6, U8 and U10) are used. These are permanently loaded with 60, 80 or 100 mg radium and vary in length from 53 to 70 mm. The applicators, C2 and C4, each containing 40 mg radium, are used for applications in cervical stumps. One applicator (C6), containing 100 mg radium, and one small (C8) and one large (C10) cylindrical applicators, containing 30 mg and 60 mg of radium respectively, are used for applications to craters. The intrauterine applicators U2 to U10, with a bent knee of 13°, and the applicators C2 to C10 are made of stainless steel. The corporal part contains a larger quantity of radium than the cervical part. The length of the applicators, the diameter, the amount of radium and the active length are given in Fig. 2. Attention should be paid to the fact that the radium in the cervical part of the applicator does not reach to the lower end,

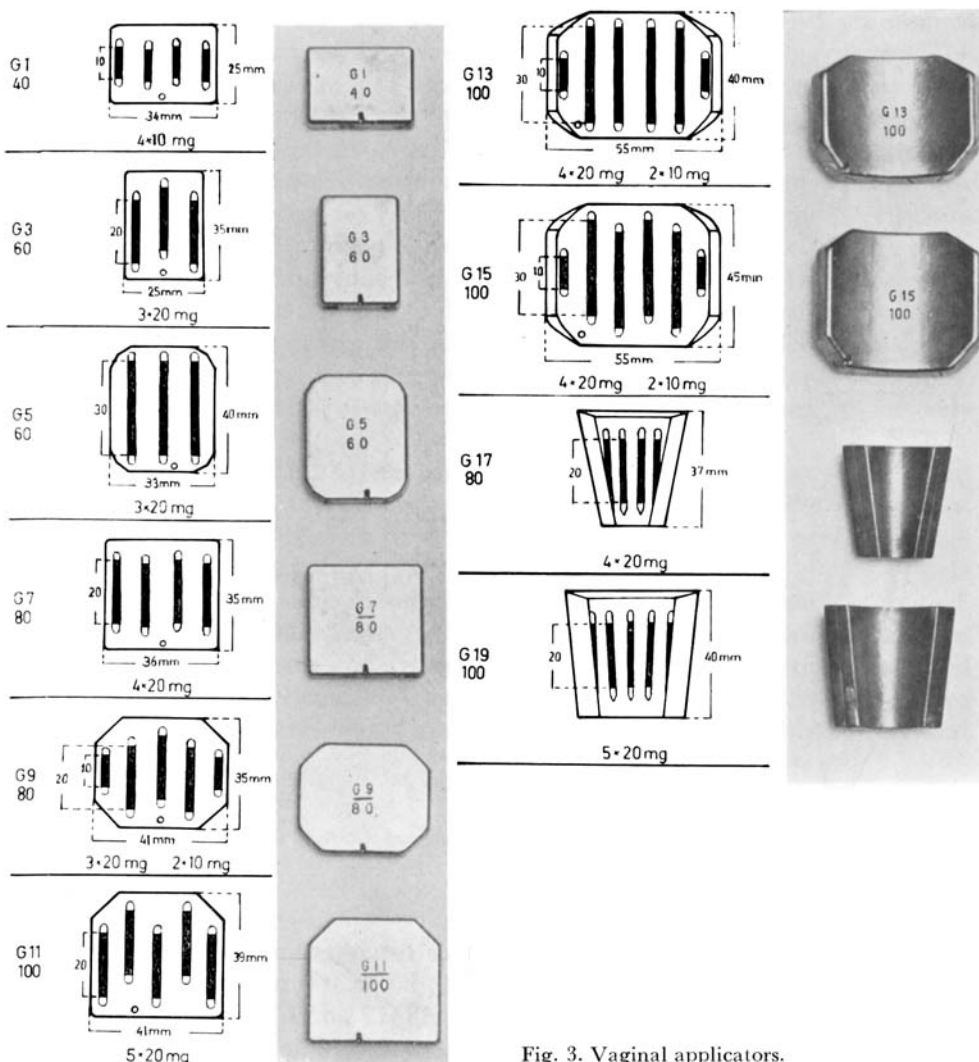
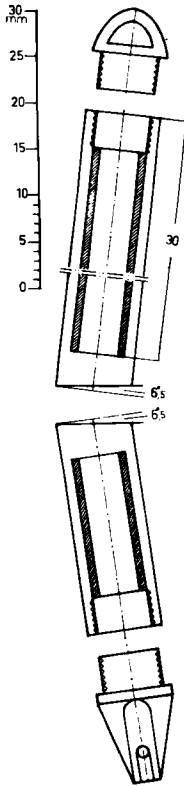

Fig. 3. Vaginal applicators.

which means that with the applicator pushed up to the fundus no radium is contained in 1.5 to 2 cm of the lower part of the cervix. The isodose curves do not therefore surround the applicators symmetrically but are displaced more towards the corporal end (Figs 6 to 15).

Six flat (G1, G3, G5, G7, G9 and G11) and four curved plaques (G13, G15, G17 and G19) are used for vaginal applications. Some have cut-off corners in order to fit into the vaginal fornices. The two plaques G13 and G15 are slightly curved in order to accommodate large tumours or a large bulky portio of a wide vagina. The curved plaques G17 and G19 are segments of the surface of



INTRAUTERINE APPLICATOR U2
100mg Ra

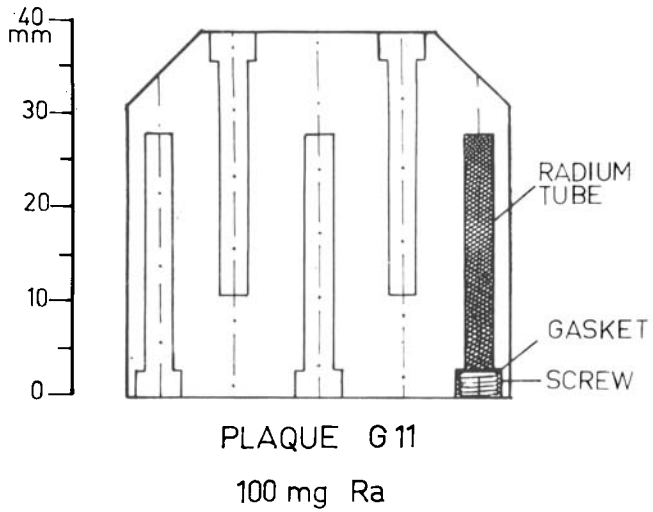

Figs 4 and 5. Constructional details of an intrauterine and a vaginal applicator.

a truncated cone and are designed to cover tumours growing down into the vagina. The plaques are loaded with 40, 60, 80 or 100 mg of radium.

The vaginal plaques, with the exception of G17 and G19, are manufactured from stainless steel and have a thickness of 8 mm. The other dimensions are given in Fig. 3. Plaques G17 and G19 are made of Monel metal. The radium tubes are inserted in drilled holes and sealed off by 0.5 mm rubber gaskets and stainless steel screws.

The total filtering equivalent of both the intrauterine and the vaginal applicators is 3 mm Pb. Constructional details of an intrauterine and a vaginal applicator are presented in Figs 4 and 5.

Measurement of the dose distribution around the applicators

The isodose curves for the intrauterine and vaginal applicators were measured in a water phantom with a scintillation detector, fitted with a small anthracene

crystal 3 mm in diameter, and mounted in a long well-polished aluminium tube to serve as light pipe between the crystal and the photo-cathode. The scintillation detector was moved along the isodose curves by means of an automatic isodose plotter developed by LARSSON et coll. The movements of the detector were reproduced by a pen that drew the isodose curves on paper.

The isodose distribution was measured in four different planes for all the vaginal plaques, excepting G13 and G15, which were measured in three planes only. The intrauterine applicators were measured in two planes and the small straight applicators in only one plane. The measuring planes were chosen to facilitate clinical evaluation of the dose distribution in the uterus, vagina and the tumour; plane 'm' gives the dose rate 2 mm from the applicator, plane 'n' the dose rate 2 cm above the plane of the radium tubes, and planes 'k' and 'l' give the dose distributions in the frontal and the sagittal planes respectively (cf. Fig. 21).

The diagrams indicate that the different intrauterine applicators give about 1 000 r per 1 000 mgh at a distance of 2 cm from the center of the applicators. The different vaginal plaques produce about 1 200 to 1 300 r per 1 000 mgh 2 cm above the surface.

All these applicators are readily sterilized and, being permanently loaded, need little handling, which reduces the total radiation hazards. Dose estimations may be made by means of isodose diagrams which are available in standardized planes around the applicators. A system of preloaded applicators with a fixed radium distribution somewhat decreases the possibility of modifying any one treatment.

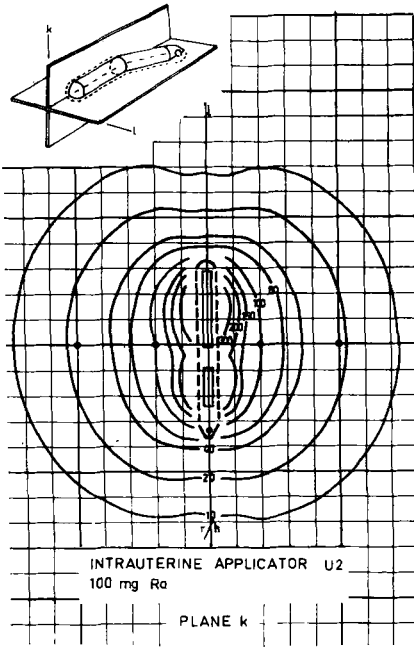

Fig. 6

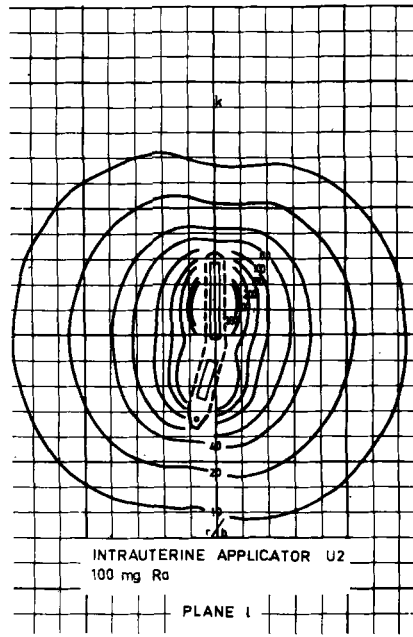

Fig. 7

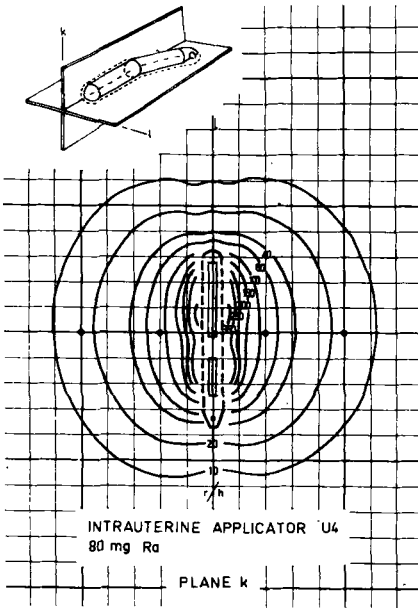

Fig. 8

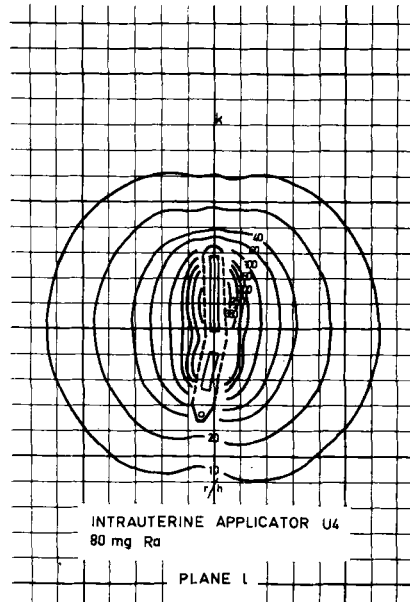

Fig. 9

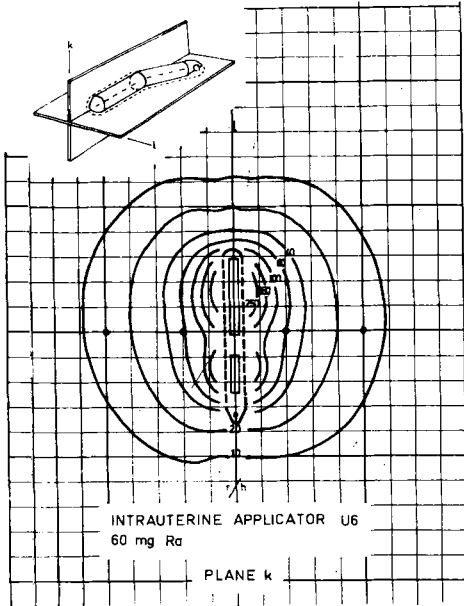

Fig. 10

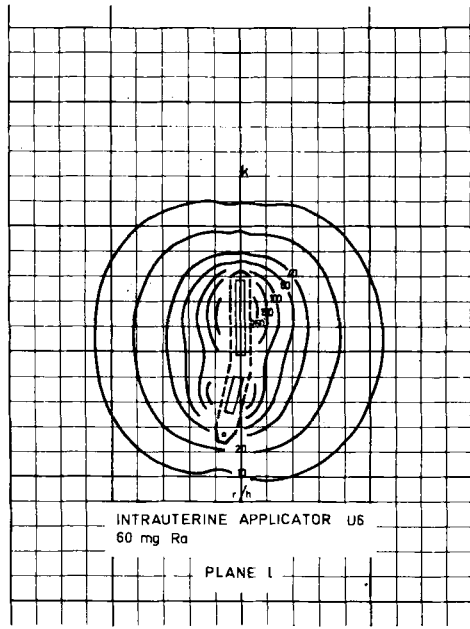

Fig. 11

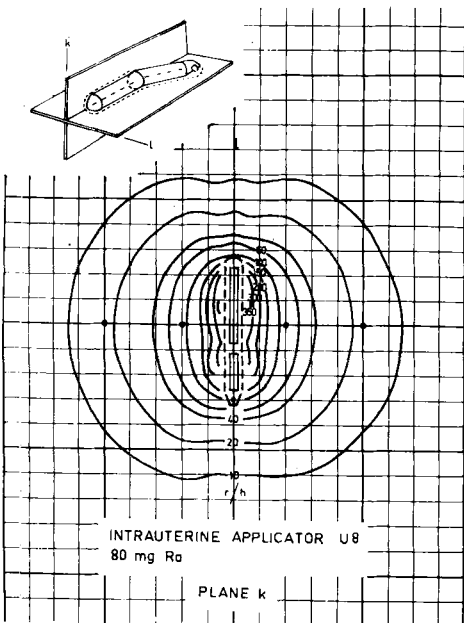

Fig. 12

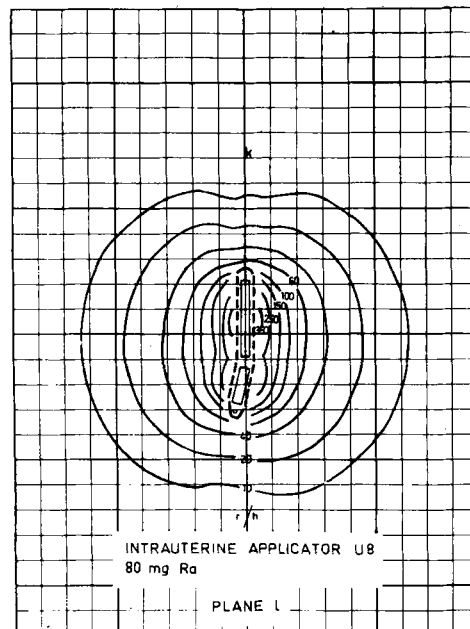

Fig. 13

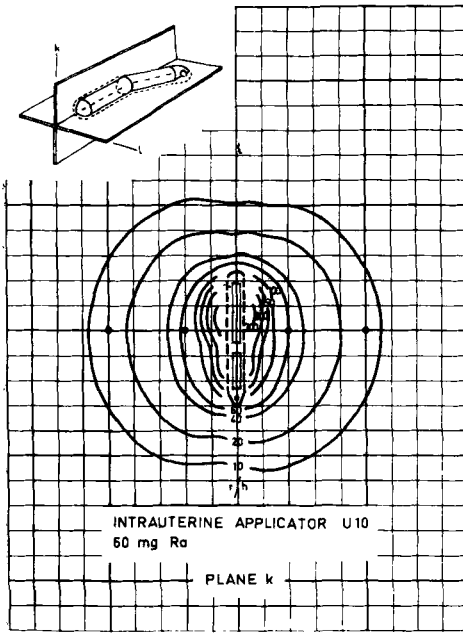

Fig. 14

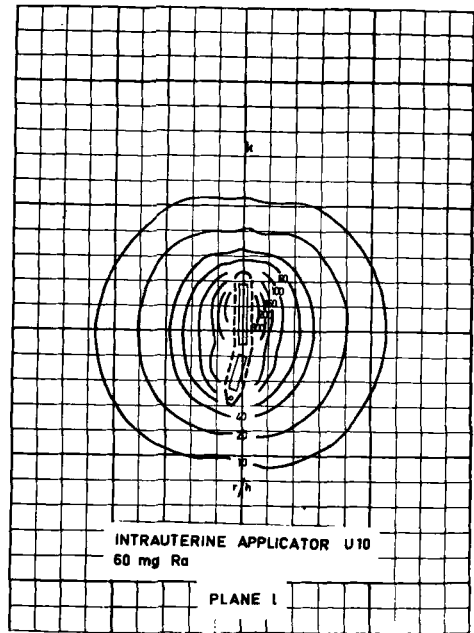

Fig. 15

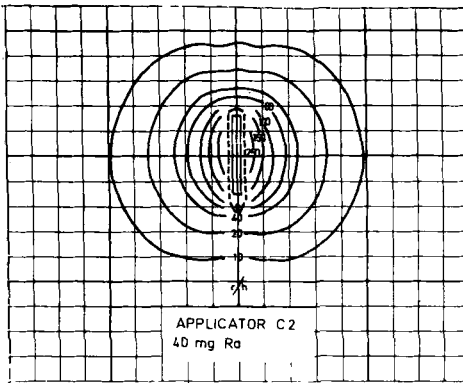

Fig. 16

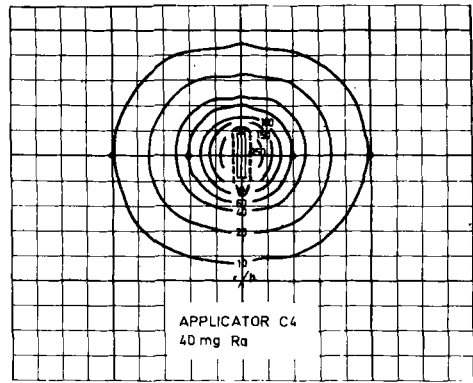

Fig. 17

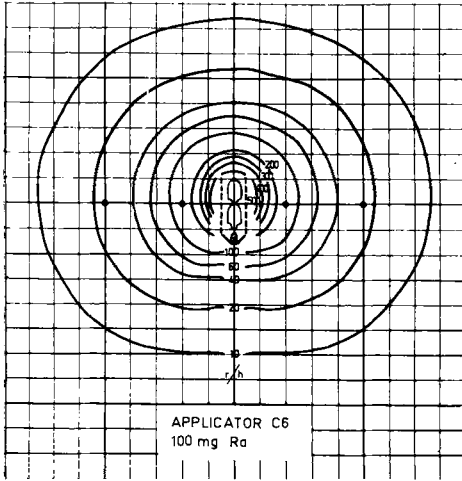

Fig. 18

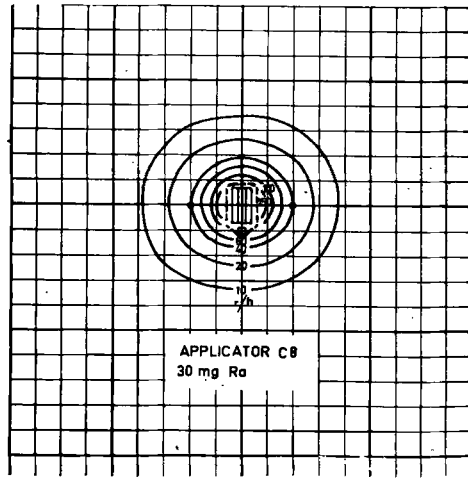

Fig. 19

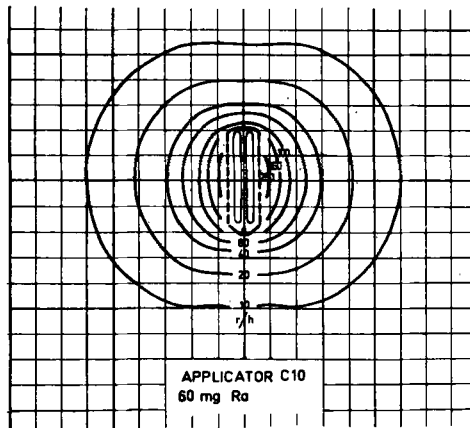

Fig. 20

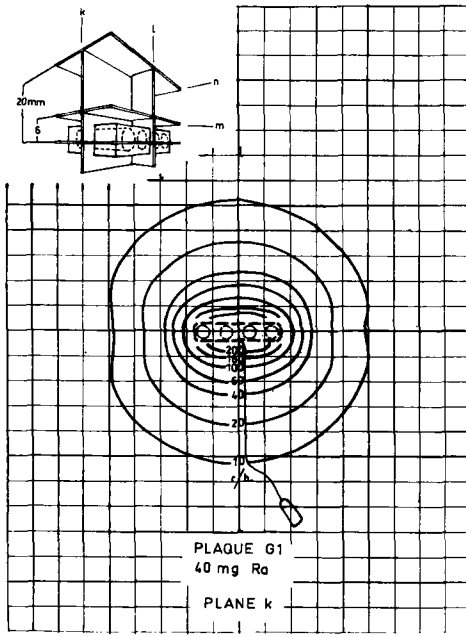

Fig. 21

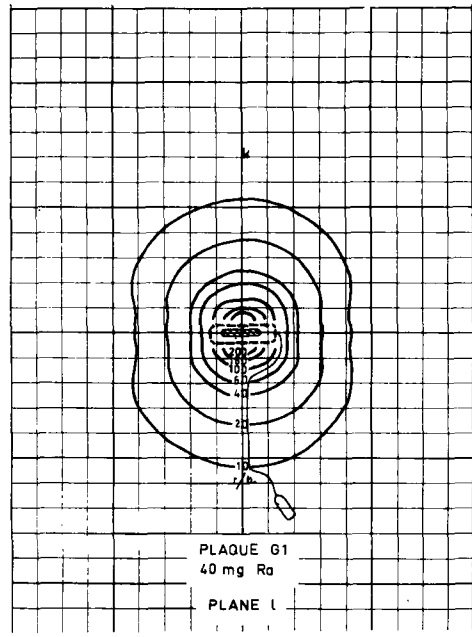

Fig. 22

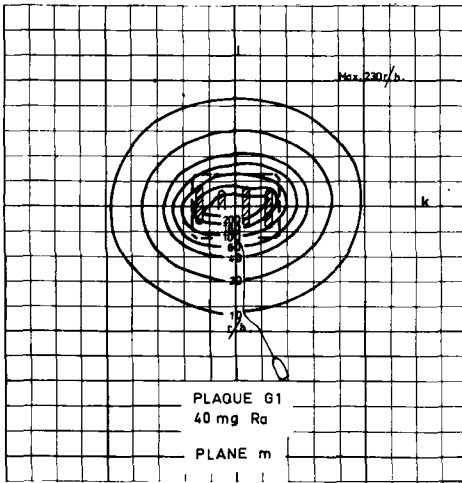

Fig. 23

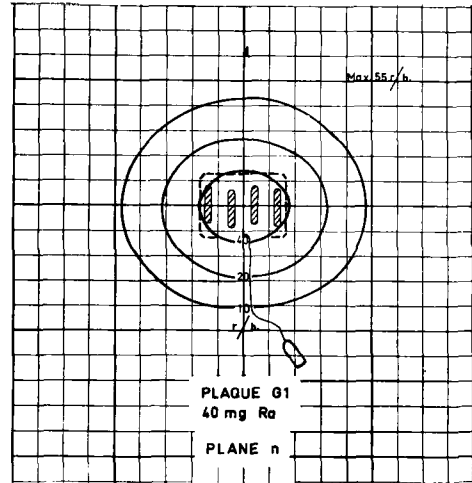

Fig. 24

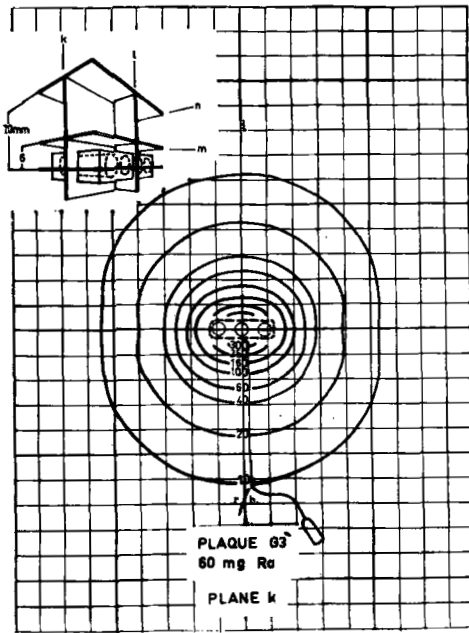

Fig. 25

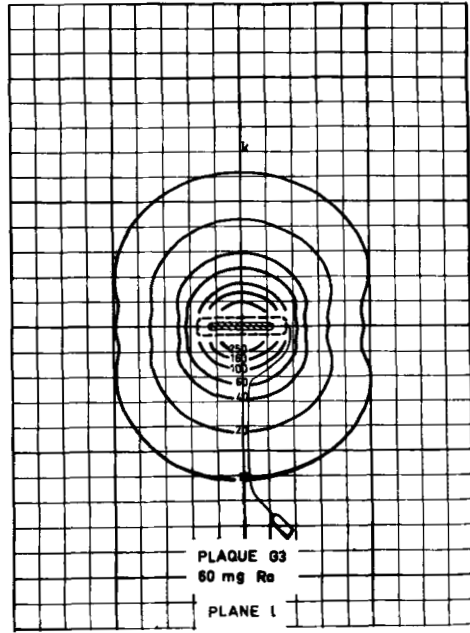

Fig. 26

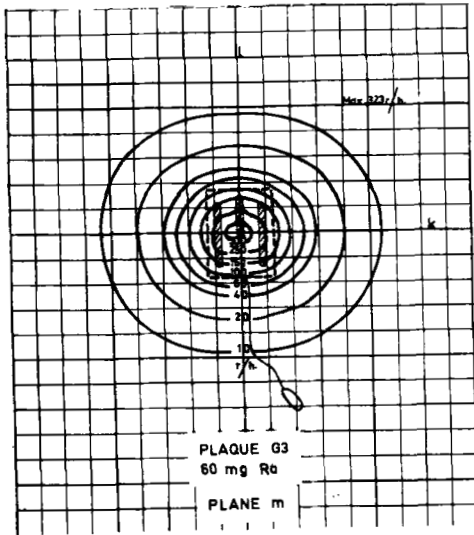

Fig. 27

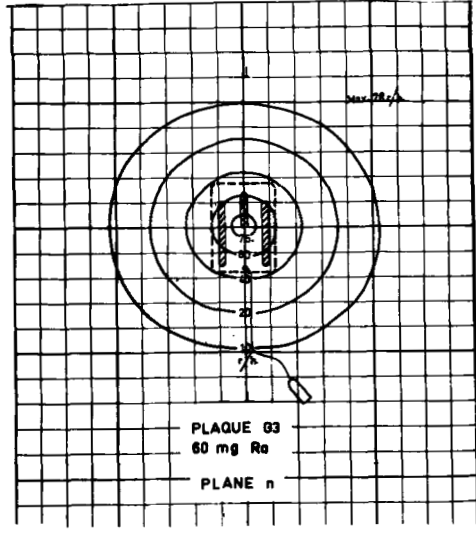

Fig. 28

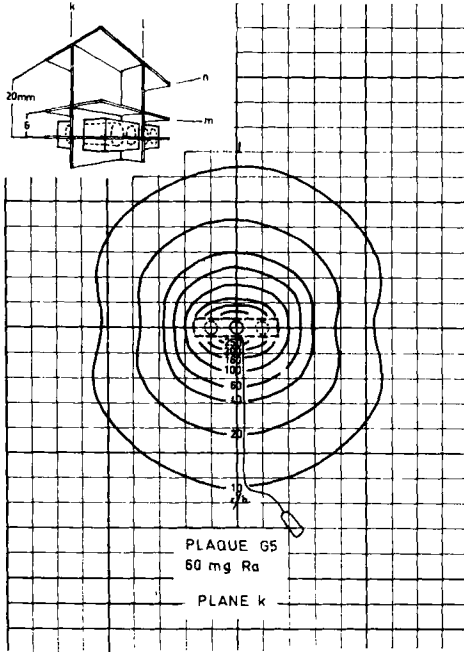

Fig. 29

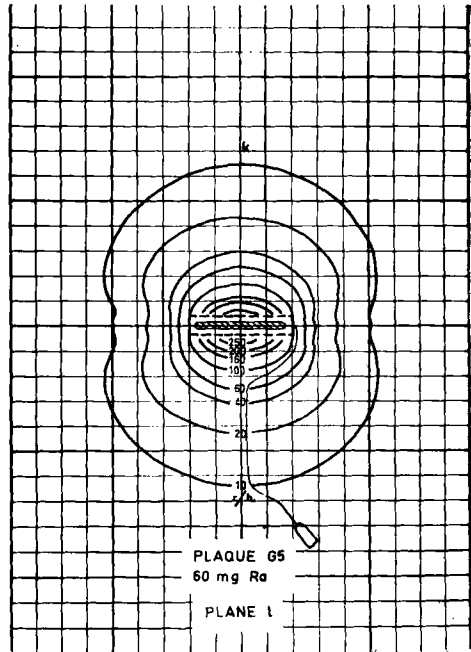

Fig. 30

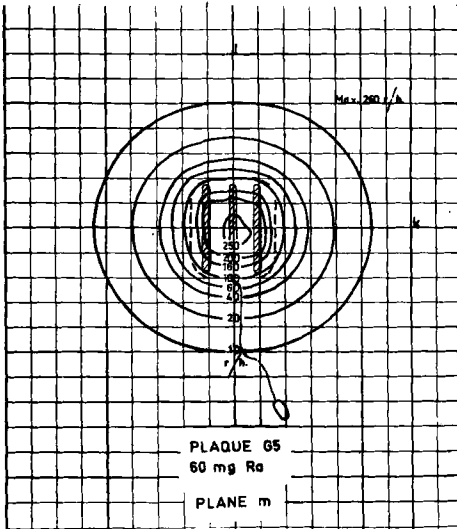

Fig. 31

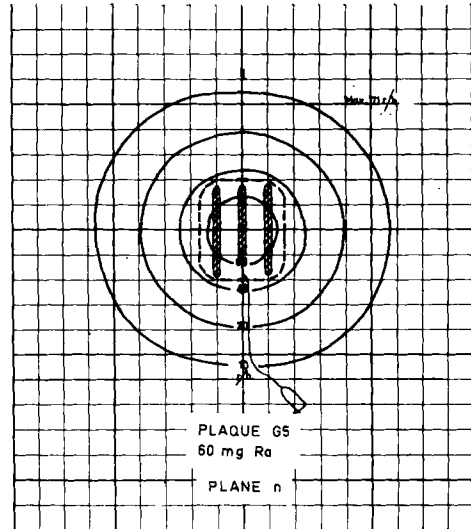

Fig. 32

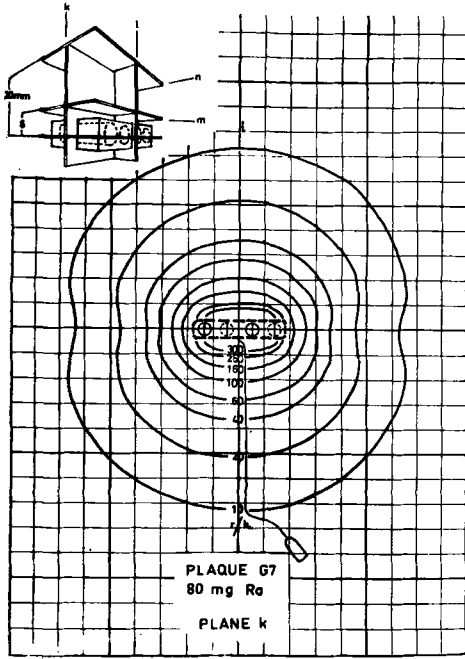

Fig. 33

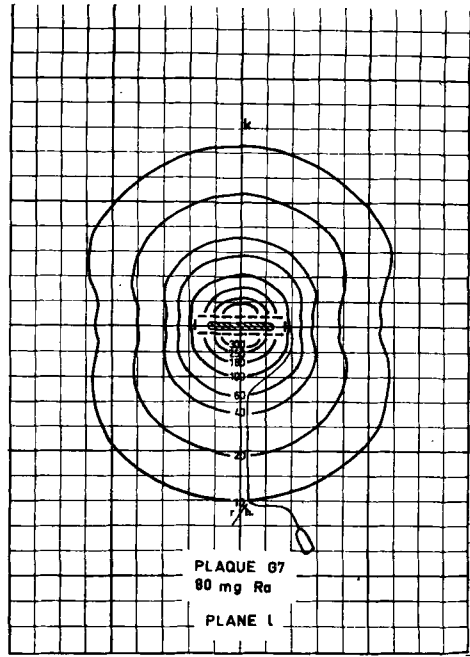

Fig. 34

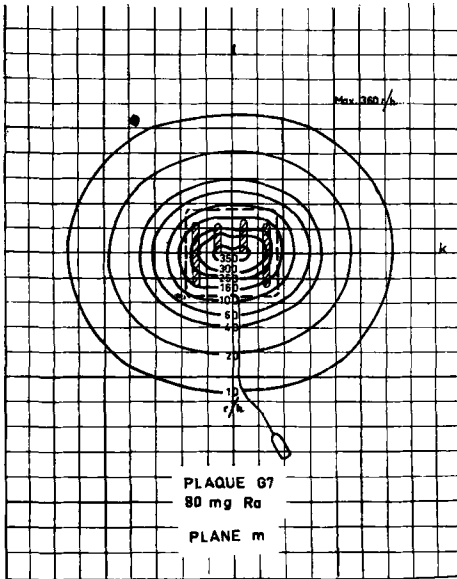

Fig. 35

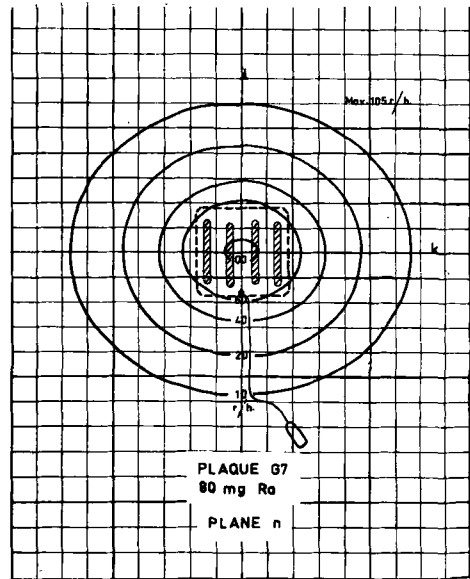

Fig. 36

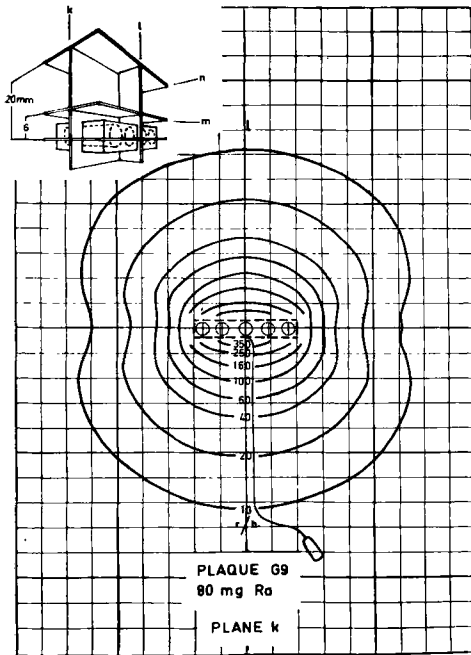

Fig. 37

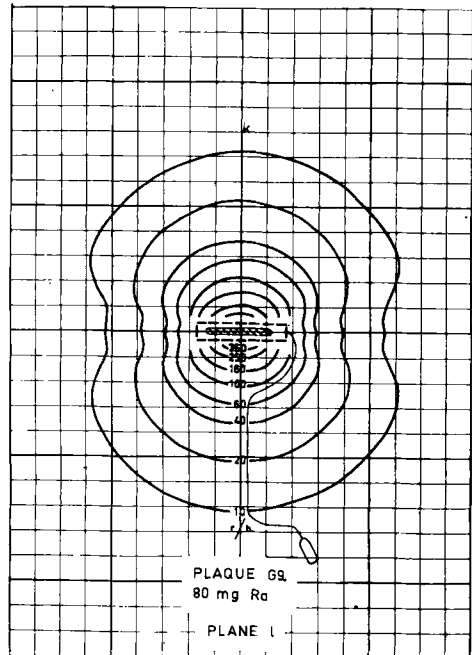

Fig. 38

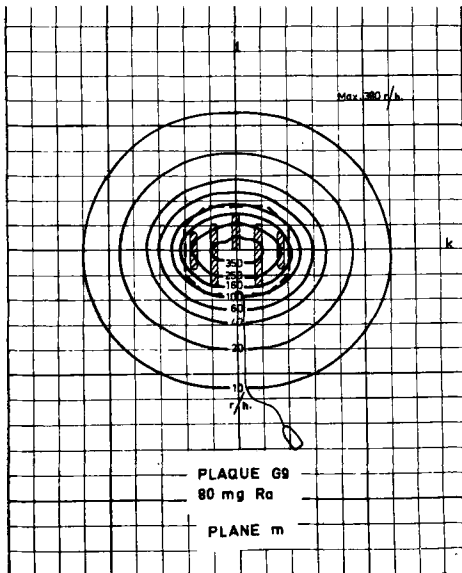

Fig. 39

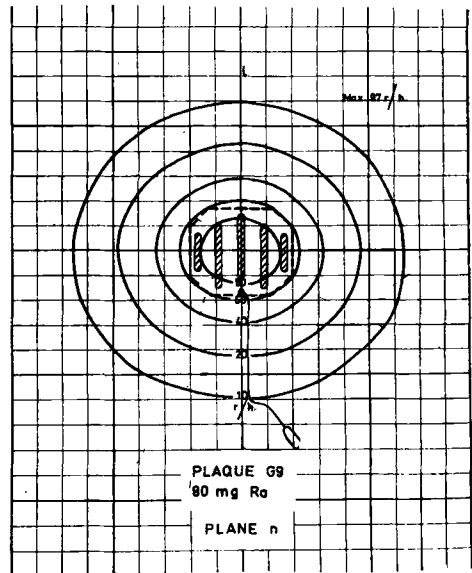

Fig. 40

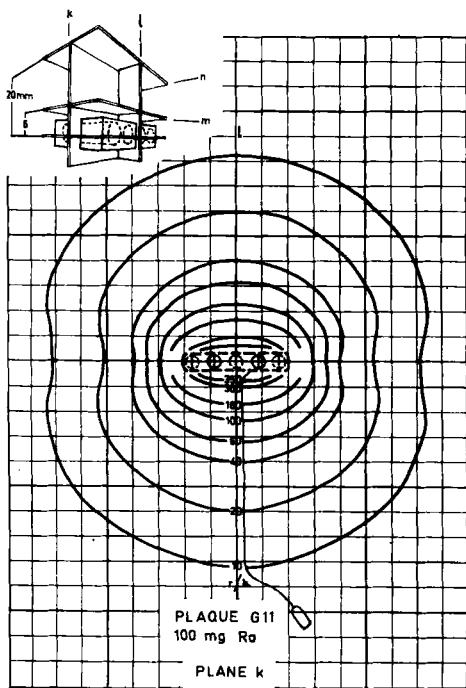

Fig. 41

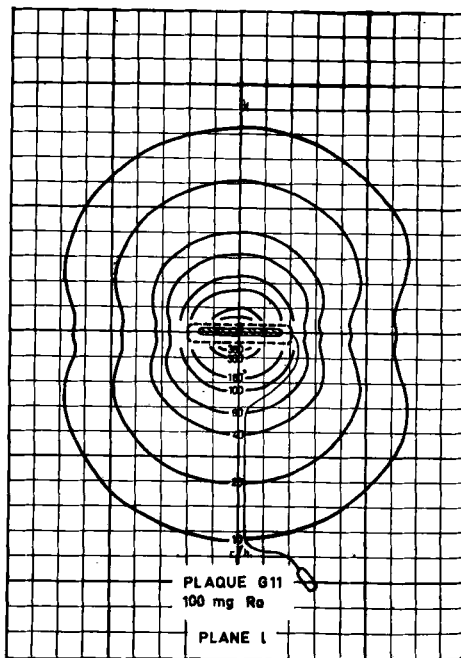

Fig. 42

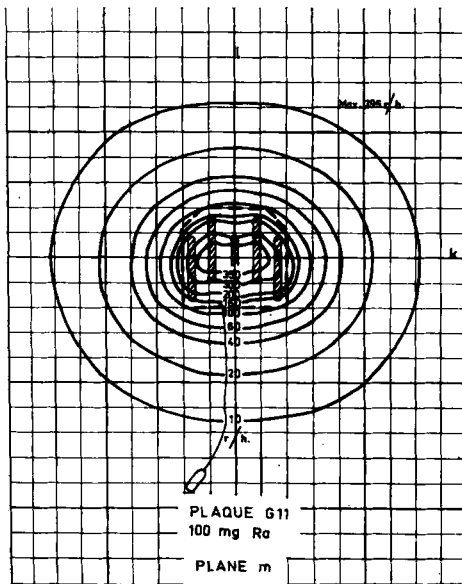

Fig. 43

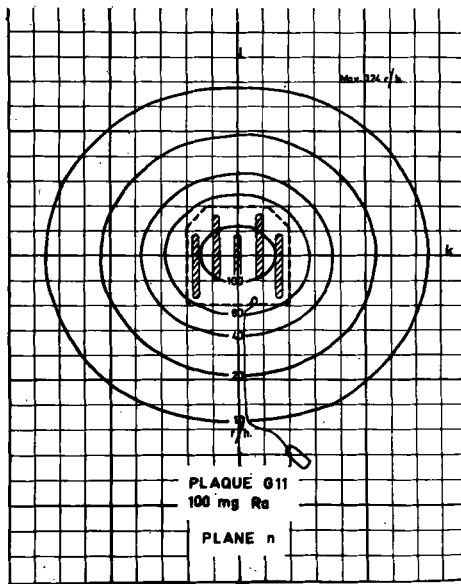

Fig. 44

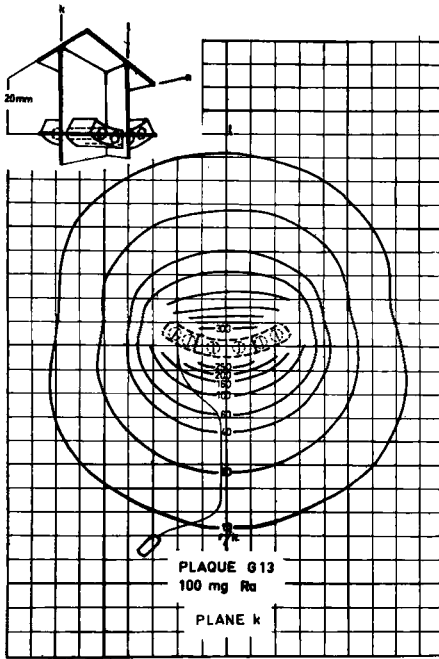

Fig. 45

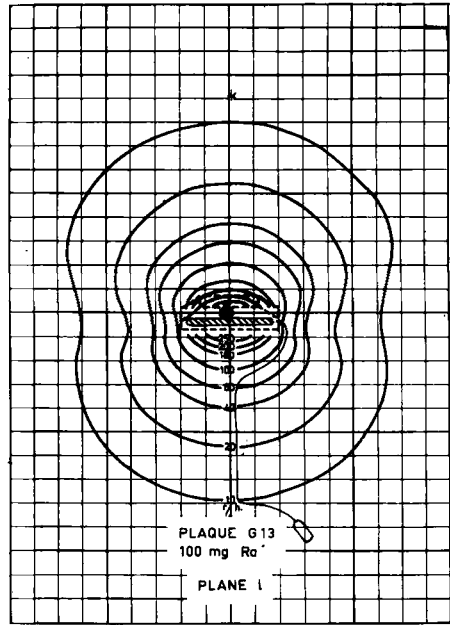

Fig. 46

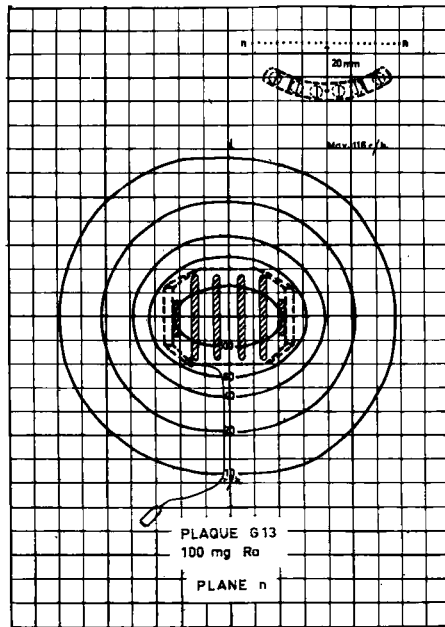

Fig. 47

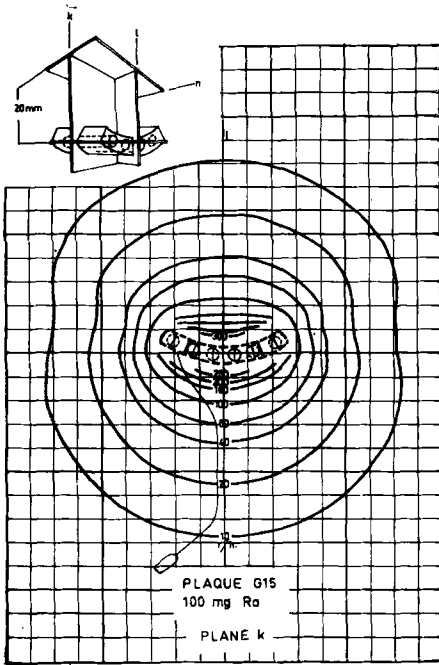

Fig. 48

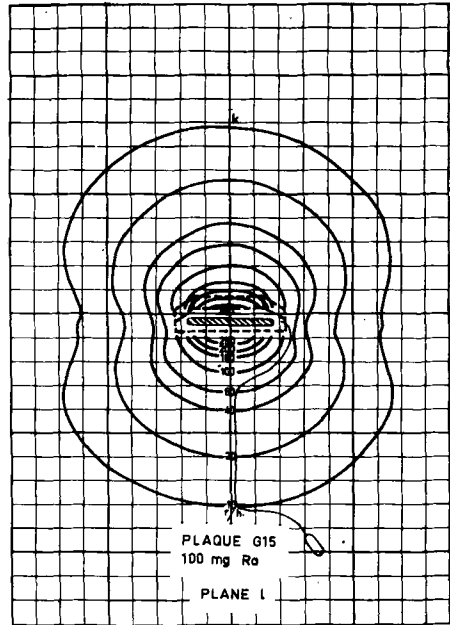

Fig. 49

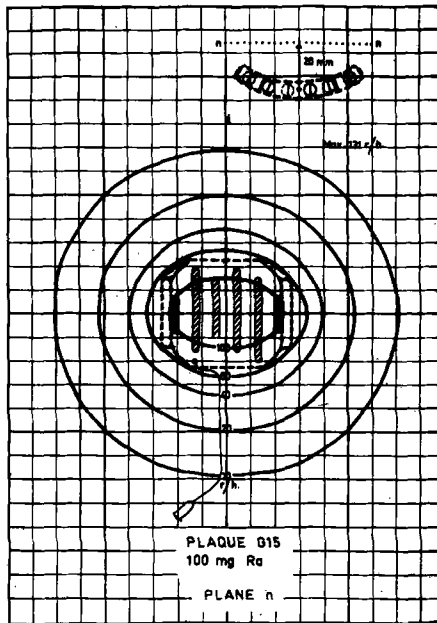

Fig. 50

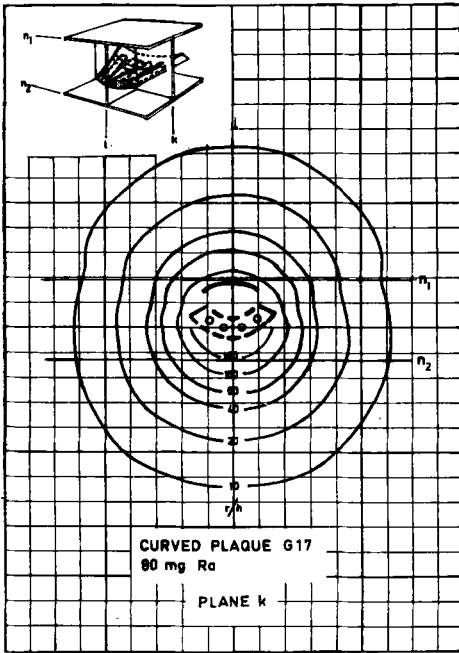

Fig. 51

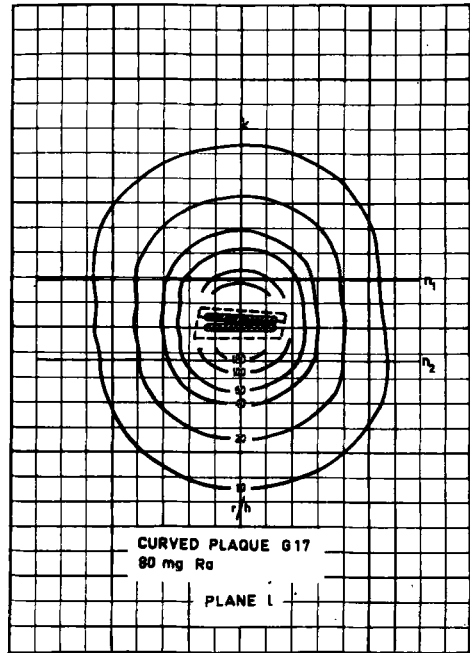

Fig. 52

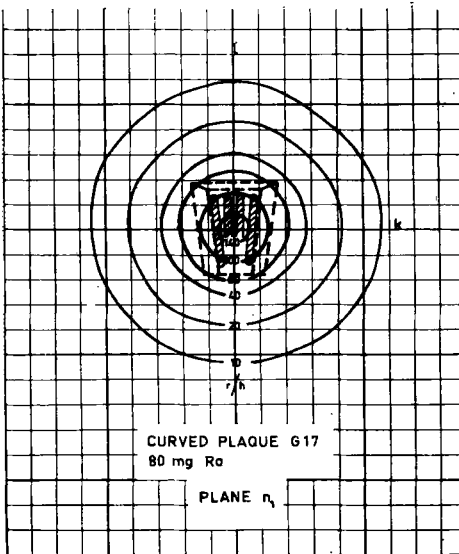

Fig. 53

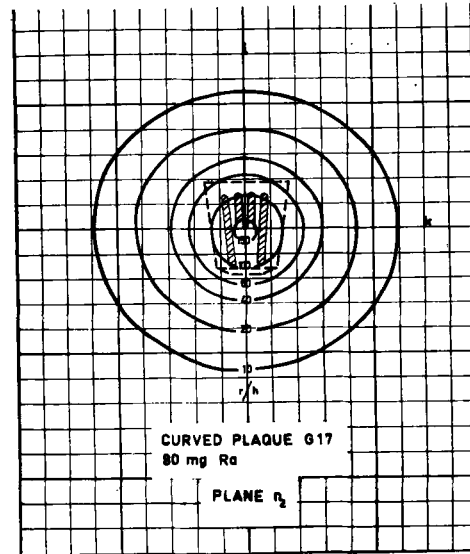

Fig. 54

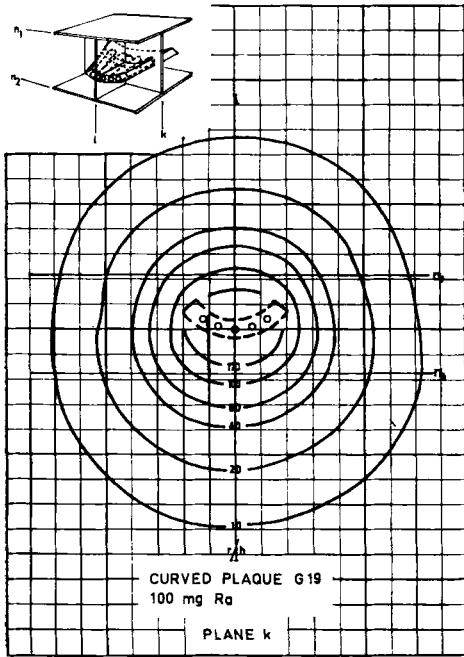

Fig. 55

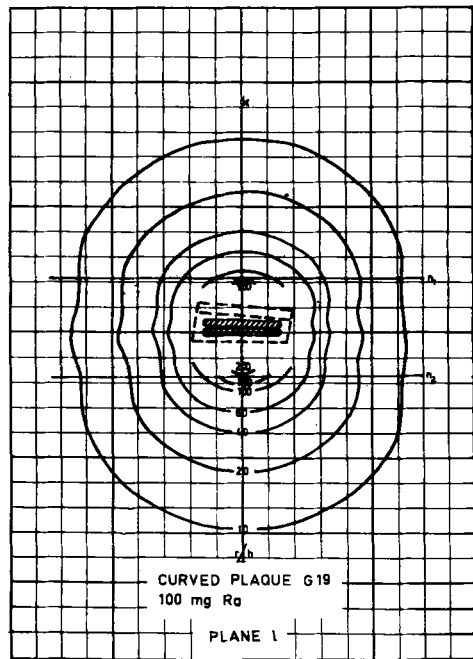

Fig. 56

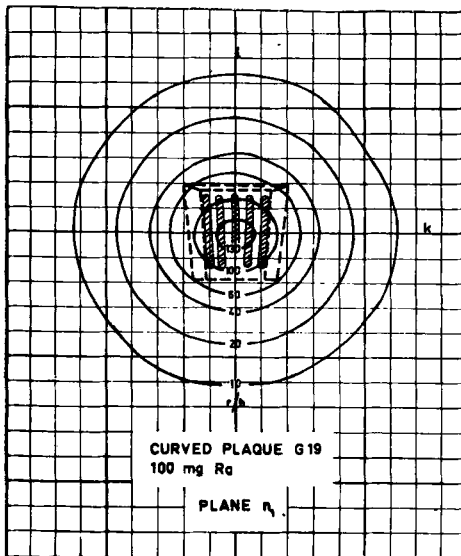

Fig. 57

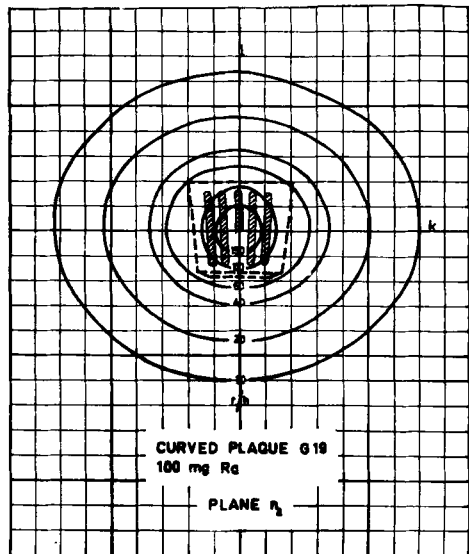

Fig. 58

SUMMARY

A system of permanently loaded applicators for the treatment of carcinoma of the cervix of the uterus is described. Isodose curves in different planes around the applicators are presented.

ZUSAMMENFASSUNG

Ein System von dauernd geladenen Radiumeinlagen zur Behandlung des Cervixkarzinoms wird beschrieben. Die Arbeit enthält die nötigen Isodosenkurven in verschiedenen Ebenen.

RÉSUMÉ

Les auteurs décrivent un système d'applicateurs chargés en permanence pour la curie-thérapie du cancer du col de l'utérus. Ils présentent les courbes isodoses dans différents plans autour des applicateurs.

REFERENCES

- GRAHAM J. B.: Progress in gynecology. Vol. 3. Grune & Stratton, New York 1957.
- SOTTO L. S. J., and PALOUCEK F. P.: Carcinoma of the cervix. W. B. Saunders, Philadelphia 1962.
- KJELLGREN O.: The radiation reaction in the vaginal smear and its prognostic significance. Acta radiol. (1958) Suppl. 168.
- KOTTMEIER H.-L.: Studies of the dosage distribution in the pelvis in radium treatment of carcinoma of the uterine cervix according to the Stockholm method. J. Fac. Radiol. 2 (1951), 312.
- Carcinoma of the female genitalia. Williams and Wilkins, Baltimore 1953.
- The role of radiotherapy in gynecology. Postgrad. Med. 25 (1959), 124.
- LARSSON I., LIDÉN K., and STARFELT M.: Automatic dose recorder. Acta radiol. Therapy—physics—biology (New series) 1 (1963), 29.
- TOD M.: Optimal dosage in the treatment of cancer of the cervix by radiation. Acta radiol. 28 (1947), 564.
- and MEREDITH W. J.: A dosage system for use in the treatment of cancer of the uterine cervix. Brit. J. Radiol 11 (1938), 809.
- WALSTAM R.: The dosage distribution in the pelvis in radium treatment of carcinoma of the cervix. Acta radiol. 42 (1954), 237.