

## RADIATION DOSES IN LOW-DOSE PELVIMETRY USING RARE-EARTH SCREENS

B. AXELSSON and H. OHLSÉN

The risk of inducing malignant neoplastic disease by the use of ionizing radiation for diagnostic purposes has been known since long.

STEWART et coll. (1958) found, in a group of children who had died of malignant tumours, an increased incidence of mothers who had been irradiated during pregnancy. Since then the consciousness of the importance of reducing the radiation dose in foetal radiography has increased.

LARSSON (1958) presented a detailed report on the gonad doses in Swedish roentgen diagnostics. With the technique used in 1955 the absorbed dose to the maternal ovaries and the foetal gonads in pelvimetry was calculated to be 10.8 mGy and 45 mGy, respectively (1 mGy = 100 mrad). These results, among other things, led to a radical change in the technique of pelvimetry (BORELL & FERNSTRÖM 1960, BORELL & RÅDBERG 1964, DIEHL & FERNSTRÖM 1966). Since the end of the sixties this simple orthodiagraphic technique has been commonly used in Sweden (BORELL & FERNSTRÖM 1967). With the introduction of ultrasound a marked decline in the frequency of obstetric radiography has occurred, except for pelvimetry. During the last years rare-earth screens have become available. These, in combination with new films, permit a further reduction of the absorbed dose (BUCHANAN et coll. 1972, RUSSEL & PRITCHARD 1975, ROSSI et coll. 1976).

One aim of the present investigation was to estimate the reduction in absorbed dose to the maternal and foetal gonads and to the foetal red bone marrow when

---

Submitted for publication 12 March 1979.

**Table 1**

*Exposure data in two different series of screen-film combinations. Total filtration 2 mm Al. Kodak processor RP X-Omat, M6-N, 36°C, 90 s*

Screen/film	Exposure data					
	Lateral			A.p.		
	kV	mA	mAs	kV	mA	mAs
Kodak X-Omatic/XH	90	250	200	55	400	200
Kodak Lanex/OG	120	100	10-16	55	100	40-50

conventional BaSO<sub>4</sub> screens were replaced by rare-earth screens. The question whether the excellent image quality obtained with the old technique was necessary for adequate clinical information prompted an investigation into the further dose reduction possible by allowing poorer, but still acceptable, image quality (low-dose technique). Another aim was to compare different rare-earth screen-film combinations using a body-phantom.

### Methods

For pelvimetry two films were exposed: One erect lateral film with field size about 25 cm × 25 cm, FFD 100 cm and one supine a.p. film with two symmetrically placed fields of the size 5 cm × 15 cm with an orthographic shift of 10 cm between the exposures and the central ray directed cranially 22.5° from the vertical; in the a.p. projection the film-cassette was placed directly under the patient.

Comparison was made primarily between two screen-film combinations: the conventional technique with Kodak X-Omatic regular screens + Kodak X-Omatic H-film (29 patients) and the low-dose technique with Kodak Lanex regular screens + Kodak Ortho G-film (10 patients). The exposure data are given in Table 1.

Using a body phantom one series of dose measurements to the rectum was performed for various screen-film combinations and exposure data. In another series the image quality was evaluated for different screen-film combinations but under constant exposure data (low-dose technique). The film processing conditions were kept constant.

*Measurements* of absorbed dose both in the patients and in the phantom series were performed using LiF-thermoluminescence dosimeters, high sensitivity ribbons with the dimension 3 mm × 3 mm × 1 mm.

Measurements of entrance and exit doses for the lateral and a.p. fields were performed with dosimeters attached to the skin of the patient. For the lateral field the absorbed dose to the rectum was measured with the dosimeter placed in a plastic tube that was inserted 10 cm into the rectum.

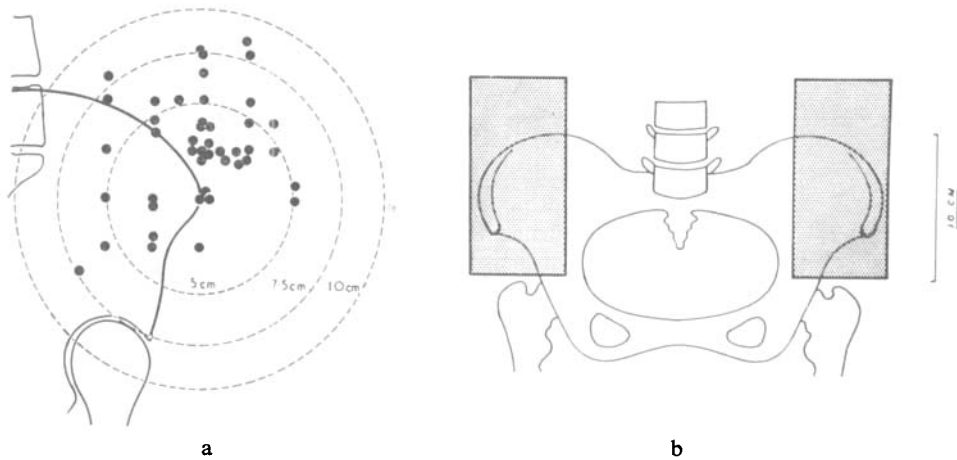

Fig. 1. Position of maternal ovaries. (From HIBBARD 1961.)

*Calculations.* The dosimeters were individually calibrated against  $^{60}\text{Co}$   $\gamma$ -radiation. Since the response is energy-dependent, correction factors had to be applied to the measured values. The effective energy of the radiation in each point of measurement was estimated from the data of the kV and filtration used. Corrections were made as suggested by RUDÉN (1975).

Data reported by SEELENTAG & KLOTZ (1959) were used in order to calculate the absorbed dose at different depths in the field and at different distances from the field limits.

The average position of the maternal ovaries was estimated from angiographic examinations in late pregnancy (OHLSON 1972), the distance between the border of the radiation field and the calculated position of the ovaries in the present series was then assessed. For the lateral field the ovaries were found to be at the upper field limit and at a depth of 8 cm from the skin. This agrees with the findings reported by HIBBARD (1961; Fig. 1). However, in the calculations the maternal ovaries were considered to be included in the primary beam of the lateral field. Concerning the position of the maternal ovaries, the absorbed dose to the rectum should be multiplied by a factor 2, due to attenuation, to estimate the mean absorbed dose to the maternal ovaries from the lateral film. For the a.p. film the ovaries were estimated to be positioned 7 to 8 cm from the field limits at a depth of 10 cm below the skin (Figs 2, 3).

The position of the foetal gonads in vertex presentation was estimated to be 20 cm cranially to the field limits. In the calculations of the mean dose to the foetal red bone marrow the distribution of marrow in the foetus according to ICRP 23 (1975) has been used. The estimated percentage of red bone marrow in the field on the two films, in the vertex and the breech presentations, are given in Table 2. The increased absorption in bone as compared to soft tissue has been accounted for in the calculation of mean bone marrow dose.

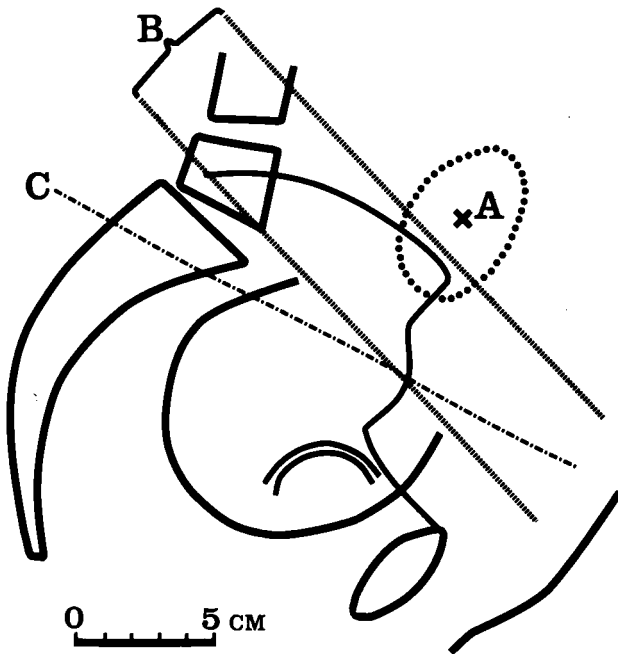

Fig. 2. Estimated average position of the maternal ovaries (A) in late pregnancy in relation to zone of the uppermost field limit in the lateral film (B) and the uppermost field limit in the a.p. film (C).

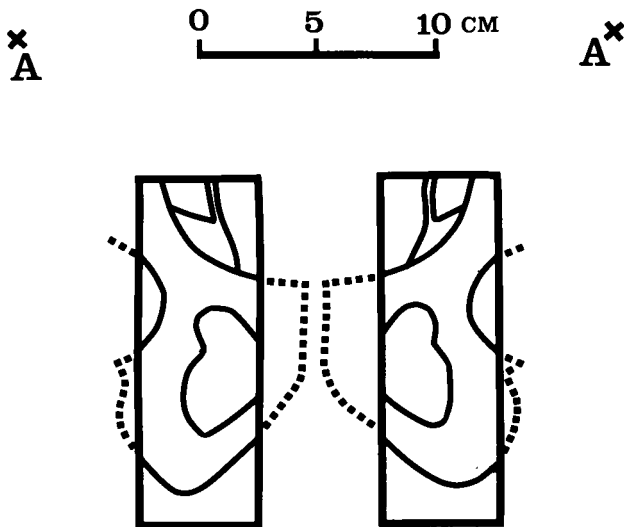

Fig. 3. A.p. Orthodiagraphic field limits. Estimated average position of maternal ovaries (A).

**Table 2**

*Percentage of foetal red bone marrow in the radiation field*

Foetal presentation	Red bone marrow	
	Lateral	A.p.
Vertex	30	0
Breech	47	8

**Table 3**

*Measured absorbed dose (mGy) in two different patient series*

Screen/film	Lateral film dose to rectum			A.p. film					
	Max.	Mean	Min.	Entrance dose			Exit dose		
				Max.	Mean	Min.	Max.	Mean	Min.
Kodak X-Omatic/XH	3.40	2.30	1.45	8.50	6.45	4.05	0.90	0.50	0.25
Kodak Lanex/OG	0.60	0.45	0.30	1.55	1.20	0.70	0.15	0.05	<0.05

**Table 4**

*Calculated mean absorbed doses to the maternal ovaries, foetal gonads and the total foetal red bone marrow*

Screen/film	Maternal ovaries		Foetal gonads				Foetal bone marrow			
	Lat.	A.p.	Vertex		Breech		Vertex		Breech	
			Lat.	A.p.	Lat.	A.p.	Lat.	A.p.	Lat.	A.p.
Kodak X-Omatic/XH	4.60	0.05	0.05	<0.01	2.30	1.50	3.20	0.20	4.80	0.60
Kodak Lanex/Ortho G	0.90	0.01	0.01	<0.01	0.45	0.30	0.60	0.05	0.90	0.10

## Results

The results of the dose measurements are given in Table 3. These values and the assumptions concerning the position of the ovaries and the foetus were used in order to estimate the absorbed dose to the maternal ovaries, the foetal gonads and the foetal red bone marrow. The results of the dose calculations are given in Table 4.

The results of the phantom measurements using different screen-film combinations appear in Table 5. The exposed films were measured with a densitometer at the same reference point. The radiographic mottle was subjectively ranked and so

**Table 5***Dose measurements in the body phantom and image quality with different screen-film combinations*

Screen/film	Exposure data		Absorbed dose to rectum (mGy)	Image quality			
	kV	mAs		Density*	Mottle**	Overall***	Densito- metry
Kodak X-Omatic regular/XH	90	200	1.00	0.80	+	0	++
Kodak X-Omatic regular/XH	120	50	0.70	0.79	+	0	+
Kodak Lanex regular/OG	120	20	0.33	0.52	0	0	0/+
Kodak Lanex regular/OG	120	16	0.22	0.44	0	0	0
Kodak Lanex regular/OG	120	10	0.13	0.40	0	0	0
Kodak Lanex regular/OH	120	10	—	0.83	+	—	0
Agfa-Gevaert MR 600/RP1	120	10	—	0.50	0	—	-/0
Agfa-Gevaert MR 600/RP2	120	10	0.07	0.72	+	—	-/0
3M Trimax Alfa 8/ Kodak OG	120	10	—	0.39	0	0	0
CEA Rarex 2/ Wicor XRP	120	10	—	0.28	—	—	—
CEA Rarex 2/RP2	120	10	—	0.44	0	—	—

\* — too low, 0 acceptable, + good.

\*\* 0 low, — medium, — — high.

\*\*\* — bad, 0 acceptable, + good, ++ excellent.

was also the overall image quality, with respect to the possibility of defining the measurement points of the pelvis.

In a clinical trial using the low-dose technique the screen-film combination of the Kodak Lanex regular and Kodak Ortho G film was compared with the Agfa-Gevaert MR 600 and RP 2 film. The first system was independently considered to be somewhat superior by three radiologists. The body phantom used for measurement was found to be an adequate test object.

### Discussion

The mean absorbed dose to the maternal ovaries using the low-dose technique is reduced to about 0.9 mGy, a substantial reduction compared to previously reported

**Table 6**  
*Radiation doses (mGy) in different reports on pelvimetry*

References	ph	p	Lateral film			A.p. film			Total maternal ovaries	Total foetal gonads (vertex)	
			kV	Maternal ovaries		Foetal gonads (breech)	io	od			Maternal ovaries
				Near-est	Dis-tant						
STANFORD & VANCE (1955)		p	120	8.4							
BEWLEY et coll. (1957)	ph		120		1*	4.0	io	5.3	6.3	30-47	
CLAYTON et coll. (1957)	ph		75	17.5	0.5		io	6.5			
LARSSON (1958)		p	90				io		10.8	45	
BORELL & FERNSTRÖM (1960)		p	120		0.9-1.6		spec.	1.5-2.8	2.4-4.4	0.1	
HAMMER-JACOBSEN (1963)		p	80				io		17.8	71.3	
REEKIE et coll. (1967)		p	118	8.0							
MATTHEWS & MILLER (1969)		p	—						4.41	7.12	
LAUTELA (1974)	ph		100	13.75	2.12	5.0	od	2.15		1.58	
LAUTELA (70 × 70 mm) (1974)	ph		70	5.52	0.54	1.8	od	1.0		0.25	
BENGTSSON et coll. (1976/77)		p	—			3.0	od		4.0	0.30	
Present series		p	90		4.6	2.3	od	0.05	4.65	0.05	
Present series (low-dose)		p	120		0.90	0.45	od	0.01	0.91	0.01	

ph = phantom. p = patient. io = inlet and outlet view. od = orthodiagraphic view.

\* ovaries considered outside beam.

results with different techniques (Table 6). The major contribution to the absorbed dose comes from the lateral exposure.

In the lateral exposure the ovaries were considered to be positioned within the primary beam, but as illustrated in Figs 2 and 3 they can in many cases be expected to lie outside the beam with a drastic further dose reduction as a consequence.

The reduction of the absorbed dose is due partly to the technique employing high tube potential and a limited ambition level concerning the image quality and partly to the use of rare-earth screen-film combination (Table 5). With materials available at present, any further significant dose reduction is not to be expected.

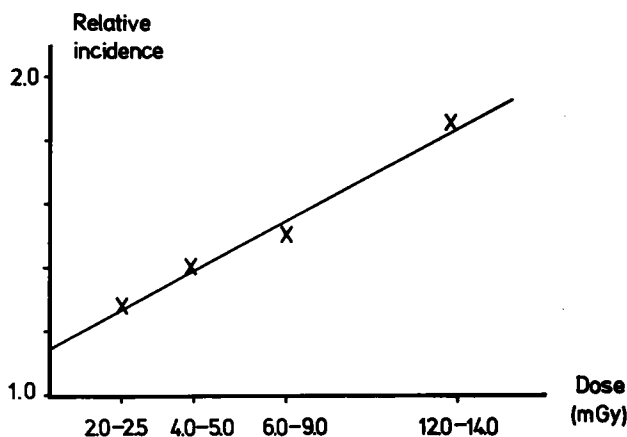

Fig. 4. Relative incidence of childhood malignancy following obstetric irradiation versus no irradiation. (From NEWCOMBE & MACGREGOR 1971.)

The radiation dose to the foetal gonads is dramatically reduced by the use of the orthodiagraphic method instead of pelvic inlet views. The orthodiagraphic principle in pelvimetry was first described by RIBBING (1932) and further developed and later recommended for measurement of the transverse diameter of the inlet (JOHANSSON 1956, SCHWARTZ 1956, JACKSON 1958). BORELL & RÅDBERG presented an easy orthodiagraphic method for measuring the interspinous and intertuberous diameters. DIEHL & FERNSTRÖM combined these methods so that the transverse diameters of both the inlet and the outlet of the pelvis could be measured directly on one a.p. film. This latter modification (the standard technique used in Sweden at present) was used in the present series.

Employing the low-dose technique reduces the foetal gonad dose in proportion to that of the maternal ovaries. As to the maternal ovaries, most of the very low absorbed dose emerged from the lateral exposure.

The risk of induction of childhood malignancy, especially leukemia, from obstetric radiography has been thoroughly evaluated by STEWART et coll. (1958), BROWN et coll. (1960), MACMAHON (1962), STEWART & KNEALE (1968, 1970). The latter authors found (1970) a linear relationship between the number of films exposed and the incidence of malignancy. By re-analysing the raw data of the latter report, a dose-response graph was calculated (Fig. 4; NEWCOMBE & MACGREGOR 1971). Extrapolating to zero dose in this graph yields a relative incidence of more than 1.0. RUSSEL (1973) pointed out that this probably reflects the fact that foetuses subjected to radiography belong to a high risk group. The hazard of every 2.0 mGy delivered will add an extra 10 per cent risk of the foetus developing malignant disease. However, it should be pointed out that these calculations have been made from materials including a large extent of views exposing the whole foetus.

For estimating the risk of leukemia the mean absorbed dose to the red bone marrow is considered relevant (ICRP 26, 1977). The calculated risk according to ICRP and the resulting number of cases with radiation sequelae per million ex-

**Table 7***Risk estimates concerning 'serious hereditary ill health' within the first two generations and leukemia*

	Risk estimates (ICRP 26) (cases/mGy)	Low dose pelvimetry (cases/million examinations)			
		Mother	Child		Breech presentation
			Vertex presentation		
'Serious hereditary ill health' within the first two generations	$10^{-5}$	9.0	—	7.5	
Leukemia	$2 \times 10^{-6}$	—	1.5	2.0	

aminations using low-dose technique in pelvimetry appear in Table 7. This means that in Sweden, with about 8 million inhabitants and about 12 000 pelvimetries per year, on the average one case of leukemia per 50-year period could be expected to be caused by low-dose pelvimetry; a low risk compared with the present figure of a mean annual incidence of leukemia of 47 cases in children below 10 years of age in the whole of Sweden.

Gonad dose levels are relevant for the discussion of the genetic risks of irradiation. Some 15 per cent of pregnancies end in abortion (ICRP 1966). The majority of spontaneous abortions are considered to be caused by genetic deficiencies either in the foetus or in the mother. The risk estimates of 'serious hereditary ill health' within the first two generations according to ICRP (1977) and the resulting number of cases per million low-dose pelvimetries are given in Table 7.

*Conclusion.* By using the low-dose technique including well coned films with orthographic technique and rare-earth screen-film combinations, the radiation dose in obstetric pelvimetry can be substantially reduced.

Considering the risks involved, for both mother and child, of not performing a pelvimetry on adequate indication, the substantial reduction of the radiation dose heavily influences the risk-benefit balance of radiologic pelvimetry.

#### Acknowledgements

The authors would like to express their thanks to Ingegerd Lundblad and Inger Roland for their help with the dose measurements.

#### SUMMARY

A 'low-dose technique' of obstetric pelvimetry, using rare-earth screens and a reduced ambition level of image quality, yields an estimated absorbed dose to the maternal and

foetal gonads of 0.9 and 0.01 mGy, respectively. The resulting risk for 'hereditary ill health' and the risk for induction of leukemia from the absorbed dose to the foetal red bone marrow, have been calculated to be at a very low level.

## ZUSAMMENFASSUNG

Eine Technik mit niedriger Dosis bei der obstetrischen Pelvimetrie, die den Gebrauch von seltenen Erden-Verstärkerfolien und ein vermindertes Ambitionsniveau der Bildqualität umfasst, gab eine berechnete absorbierte Dosis zu den mütterlichen und den fötalen Gonaden von 0,9 bzw. 0,01 mGy. Das sich ergebene berechnete Risiko für einen hereditären Krankheitszustand und das Risiko für die Induktion einer Leukämie durch die absorbierte Strahlung im fötalen roten Blutmark war sehr niedrig.

## RÉSUMÉ

Une technique de pelvimétrie obstétricale à faible dose, comprenant l'utilisation d'écrans aux terres rares et des exigences réduites concernant la qualité de l'image donne une dose absorbée estimée aux gonades maternelles et fœtales de 0,9 et 0,01 mGy, respectivement. D'après les calculs, le risque de mauvaise santé héréditaire et le risque d'induction d'une leucémie résultant de la dose absorbée par la moelle osseuse rouge fœtale sont à un très faible niveau.

## REFERENCES

- BENGTSSON G.: Personal communication (1976).
- BLOMGREN P.-G., BERGMAN K. and ÅBERG L.: Patient exposures and radiation risks in Swedish diagnostic radiology. SSI report 027 (1977).
- BEWLEY D. K., LAWS J. W. and MYDDLETON C. J.: Maternal and foetal radiation dosage during obstetric radiographic examinations. *Brit. J. Radiol.* 30 (1957), 286.
- BORELL U. and FERNSTRÖM I.: Radiologic pelvimetry. *Acta radiol.* (1960) Suppl. No. 191
- — Geburtshilfliche Röntgendiagnostik. *In: Gynäkologie und Geburtshilfe. Band II*, p. 290. George Thime Verlag, Stuttgart 1967.
- and RÅDBERG C.: Orthodiagraphic pelvimetry with special reference to capacity of distal part of pelvis and pelvic outlet. *Acta radiol. Diagnosis 2* (1964), 273.
- BROWN W. M. C., DOLL R. and HILL B.: Incidence of leukemia after exposure to diagnostic radiation in utero. *Brit. med. J.* 2 (1960), 1539.
- BUCHANAN R. A., FINKELSTEIN S. I. and WICKERSHEIM K. A.: X-ray exposure reduction using rare-earth oxysulfide intensifying screens. *Radiology* 105 (1972), 185.
- CLAYTON C. G., FARMER F. T. and WARRICK C. K.: Radiation doses to the foetal and maternal gonads in obstetric radiography during late pregnancy. *Brit. J. Radiol.* 30 (1957), 291.
- DIEHL J. and FERNSTRÖM I.: Radiologic pelvimetry with special reference to widest transverse diameter of pelvic inlet. *Acta radiol. Diagnosis 4* (1966), 557.
- HAMMER-JACOBSEN E.: Genetically significant radiation doses in diagnostic radiology. *Acta radiol.* (1963) Suppl. No. 222.
- HIBBARD B. M.: The position of the maternal ovaries in late pregnancy. *Brit. J. Radiol.* 34 (1961), 387.
- ICRP (International Commission on Radiological Protection): The evaluation of risks from radiation. 1966.

- Report of the Task Group on Reference Man, 1975.
- Recommendations of the International Commission on Radiological Protection, 1977. Pergamon Press, Oxford.
- JACKSON J.: Pelvimetry: a low irradiation technique for the transverse measurements. *Med. Proc.* 4 (1958), 541.
- JOHANSSON C. E.: Radiology in obstetrics. *Acta obstet. gynec. scand.* 35 (1956), 181.
- LARSSON L.-E.: Radiation doses to the gonads of patients in Swedish roentgen diagnostics. *Acta radiol.* (1958) Suppl. No. 157.
- LAUTELA I.: Pelvimetry with image intensifier camera. *Acta radiol.* (1974) Suppl. No. 341.
- MACMAHON B.: Pre-natal X-ray exposure and childhood cancer. *J. nat. Canc. Inst.* 28 (1962), 1173.
- MATTHEWS J. C. and MILLER H.: Radiation hazards from diagnostic radiology. A repeat survey over a small area. *Brit. J. Radiol.* 42 (1969), 814.
- NEWCOMBE H. B. and MCGREGOR J. F.: Childhood cancer following obstetric radiography. *Lancet* II (1971), 1151.
- OHLSON L.: Coordinate topographic recordings in the abdomen. The ovarian artery as an indicator of the expansion of the uterus in pregnancy. *Acta radiol. Diagnosis* 12 (1972), 705.
- REEKIE D., DAVISON M. and DAVIDSON J. K.: The radiation hazard in radiography of the female abdomen and pelvis. *Brit. J. Radiol.* 40 (1967), 849.
- RIBBING S.: Beitrag zur röntgenologischen Pelvimetrie und Zephalometrie in Utero. *Acta radiol.* 13 (1932), 591.
- ROSSI R. P., HENDIE W. R. and AHRENS C. R.: An evaluation of rare earth screen/film combinations. *Radiology* 121 (1976), 465.
- RUDÉN B.-I.: Some applications of thermoluminescence dosimetry in medical and health physics. Thesis, Stockholm (1975).
- RUSSEL J. G. B.: Radiology in Obstetrics and Antenatal Paediatrics. Butterworths, London 1973.
- and PRITCHARD C. A.: Foetal radiography. *Lancet* II (1975), 768.
- SCHWARZ G. S.: An orthometric radiograph for obstetrical roentgenometry. *Radiology* 66 (1956), 753.
- SEELENTAG W. und KLOTZ E.: Die Streustrahlung im Körper bei Strahlenqualitäten von 50 bis 200 kV Erzeugerspannung. *Strahlentherapie* 108 (1959), 112.
- STANFORD R. W. and VANCE J.: The quantity of radiation received by the reproductive organs of patients during routine diagnostic X-ray examinations. *Brit. J. Radiol.* 28 (1955), 266.
- STEWART A. and KNEALE G. W.: Changes in the cancer risk associated with obstetric radiography. *Lancet* I (1968), 104.
- — Radiation dose effects in relation to obstetric X-rays and childhood cancers. *Lancet* I (1970), 1185.
- WEBB J. and HEWITT D.: A survey of childhood malignancies. *Brit. med. J.* 2 (1958), 1495.